

91890 92026 88480  
88481 38220

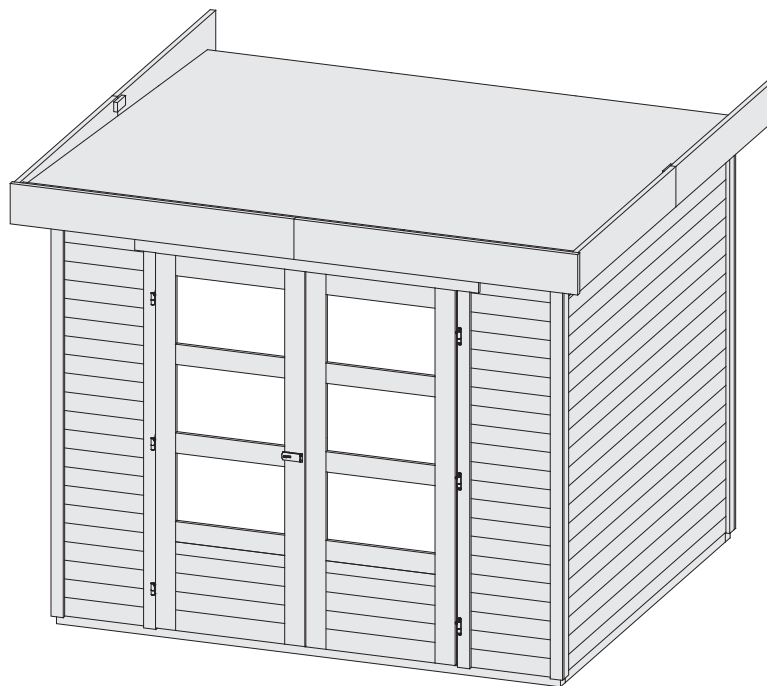

-  **Aufbauanleitung**
-  **Building Instructions**
-  **notice de montage**
-  **montagehandleiding**
-  **Montagevejledning**
-  **Instrucciones de construcción**
-  **Istruzioni per il montaggio**
-  **Montážní návod**

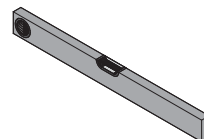

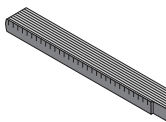
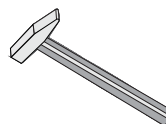
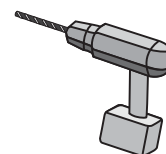
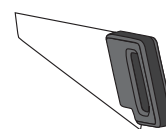

Vergleichen Sie zuerst die Materialliste mit Ihrem Paketinhalt! Bitte haben Sie Verständnis, dass Beanstandungen nur im **nicht aufgebauten** Zustand bearbeitet werden können!



En primer lugar, compare la lista de material con el contenido del paquete. Rogamos entienda que las reclamaciones sólo pueden ser tramitadas **antes de montar el objeto!**



Nejprve překontrolujte obsah balení podle materiálového listu! Mějte pochopení pro to, že případnou reklamaci se můžeme zabývat pouze tehdy, když díly nebudou smontované! Za pomoci tohoto seznamu můžete jednotlivé díly přiřadit k montážnímu návodu.



Vergelijk eerst de lijst van materialen met de inhoud van uw pakket! Reclamaties kunnen alleen in behandeling worden genomen zolang de onderdelen nog niet zijn gemonteerd!



First compare the list of materials with your package contents! Please understand that complaints can be processed in the **non-built** status only!





Commencez par comparer la liste du matériel avec le contenu de votre paquet! Sachez que nous traitons uniquement les réclamations concernant le matériel à l'état **non monté!**

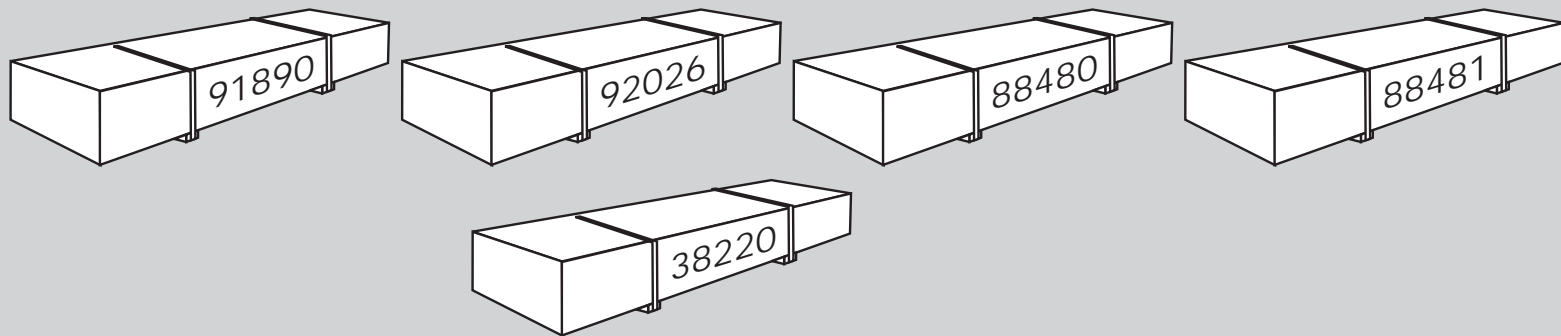

Confrontate questa distinta materiali prima con il contenuto del pacchetto! Vi preghiamo di comprendere che eventuali reclami possono essere accolti solo prima del montaggio!

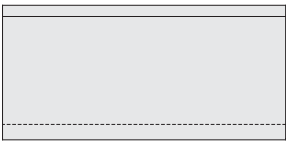

		
42 x U1	478 x 96 x 19mm	ID 73741
42 x U2	2090 x 96 x 19mm	ID 43927
24 x U3	2380 x 96 x 19mm	ID 44696

		
1 x P1	2090 x 172 x 19mm	ID 61300
1 x P2	2090 x 172 x 19mm	ID 61301

		
10 x	4 x 16mm	ID 3690
750 x	4 x 30mm	ID 3686
850 x	4 x 50mm	ID 3688
50 x	4,5 x 80mm	ID 9204

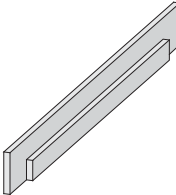
		
1 x H1	1650 x 120 x 36mm	ID 73738

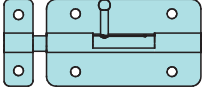
2 x		ID 3709
-----	---------------------------------------------------------------------------------------	---------

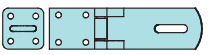
1 x		ID 3724
-----	---------------------------------------------------------------------------------------	---------

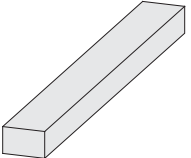
		
-------------------------------------------------------------------------------------	--	--

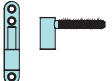
6 x		ID 3717
-----	---------------------------------------------------------------------------------------	---------

2 x B1	1755 x 36 x 18mm	ID 73740
6 x B2	100 x 45 x 18mm	ID 19114
6 x B3	240 x 45 x 18mm	ID 16392
1 x B4	1390 x 45 x 18mm	ID 58371
1 x B5	1737 x 45 x 18mm	ID 19205
2 x B6	1755 x 45 x 18mm	ID 59227
6 x B7	1800 x 45 x 18mm	ID 19546
2 x B8	1760 x 58 x 18mm	ID 71960
4 x B9	1980 x 58 x 18mm	ID 38947
4 x B10	2100 x 58 x 18mm	ID 28029
2 x B11	2100 x 95 x 18mm	ID 11427
1 x B12	1650 x 120 x 18mm	ID 58005
4 x B13	1225 x 190 x 26mm	ID 73804
2 x B14	1340 x 190 x 26mm	ID 67623
3 x B15	2343 x 95 x 36mm	ID 55860
5 x B16	1950 x 45 x 38mm	ID 41511
2 x B17	2000 x 45 x 38mm	ID 18358
4 x B18	2400 x 60 x 40mm	ID 19332

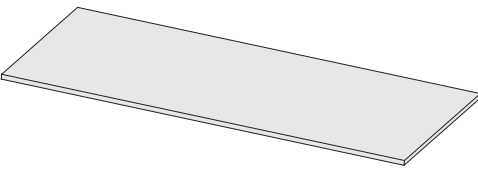
		
3 x N1	870 x 610 x 16mm	ID 58037
3 x N2	1740 x 870 x 16mm	ID 45414

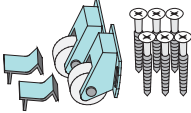
1 x		ID 68586
-----	---------------------------------------------------------------------------------------	----------

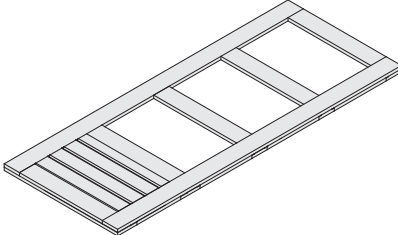
		
1 x D1	1765 x 705 x 36mm	ID 73736
1 x D2	1765 x 705 x 36mm	ID 73737

1 x		ID 16034
-----	-------------------------------------------------------------------------------------	----------

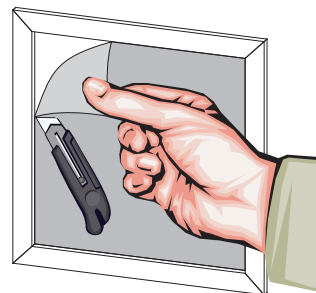

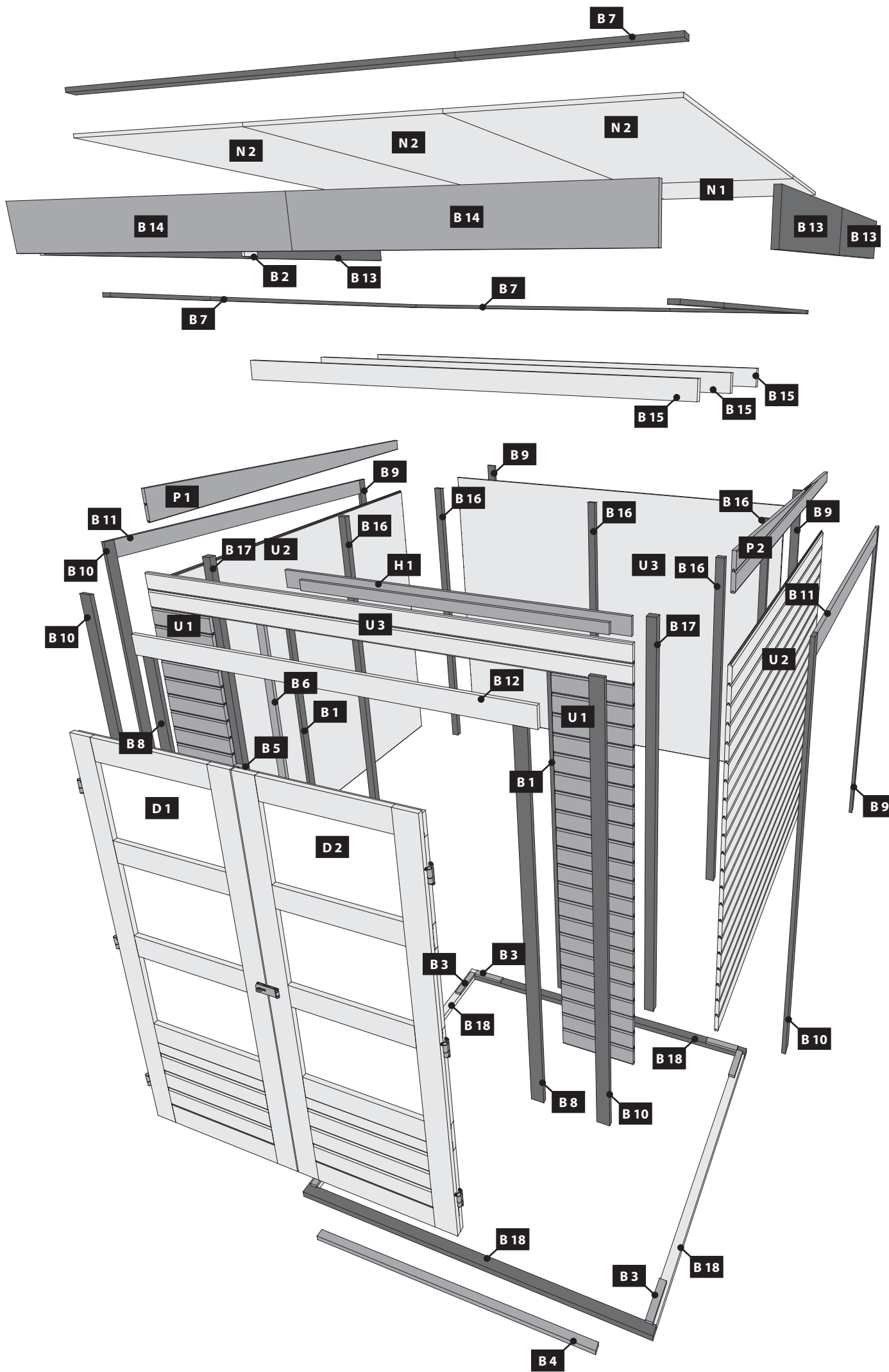

01 2x

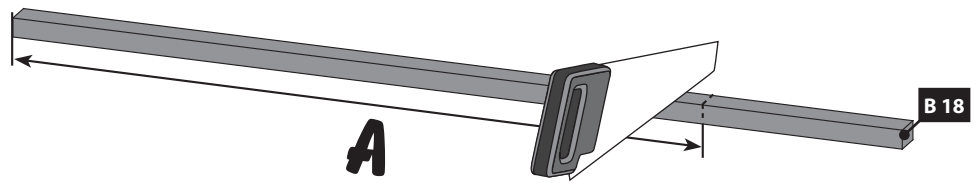

2x

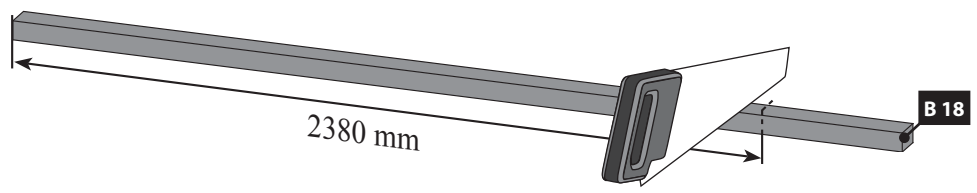

02

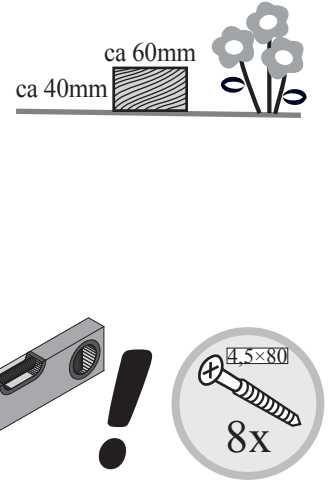
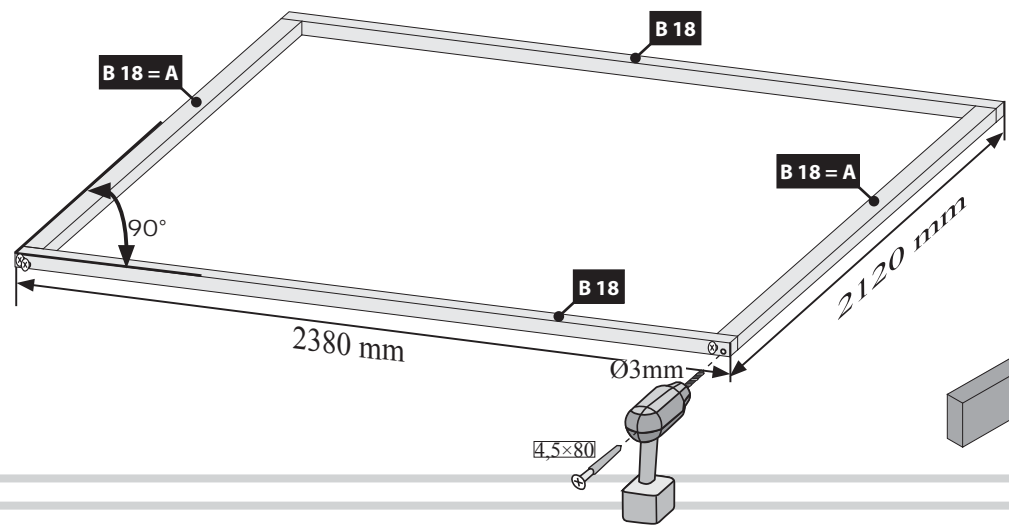

03

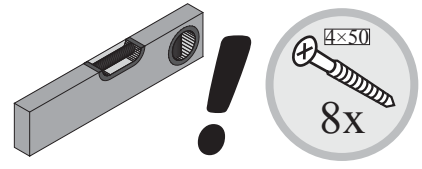
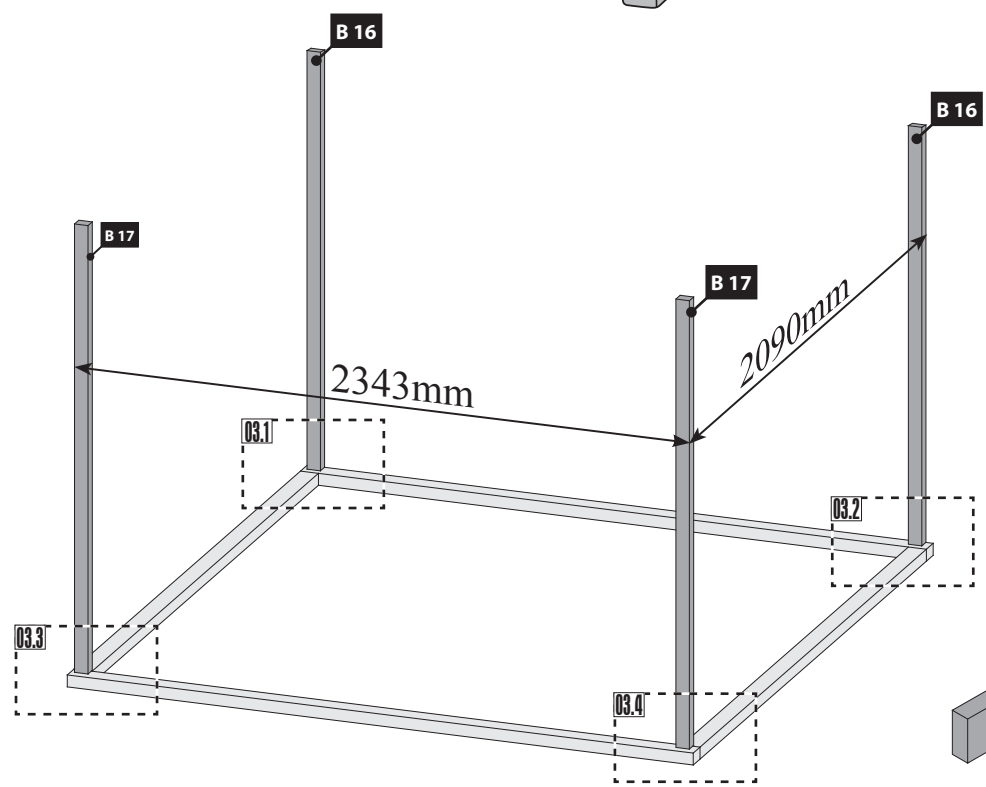

03.1

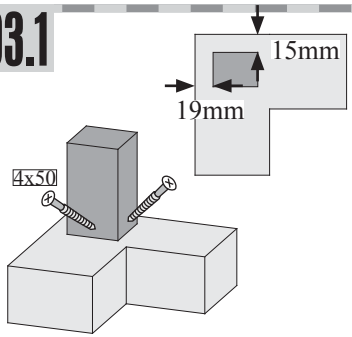

03.2

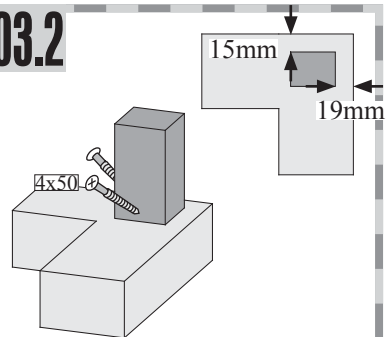

03.3

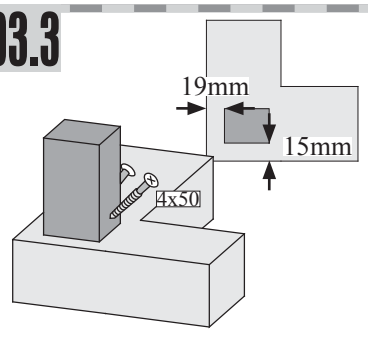

03.4

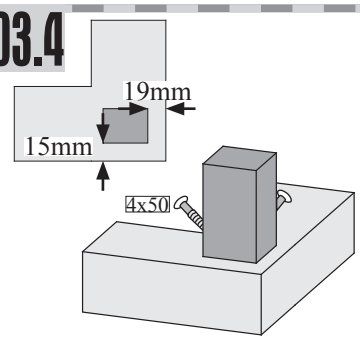

 Leim! Achten Sie auf die gleiche Höhe  
 Glue! Look for the same height  
 Colle! Faites attention à la même hauteur

 Lijm! Besteed aandacht aan de dezelfde hoogte  
 Pegamento! Prestar atención a la misma altura  
 Colla! Prestare attenzione alla stessa altezza

 Klíž! Dávejte pozor na stejnou výšku



**04**

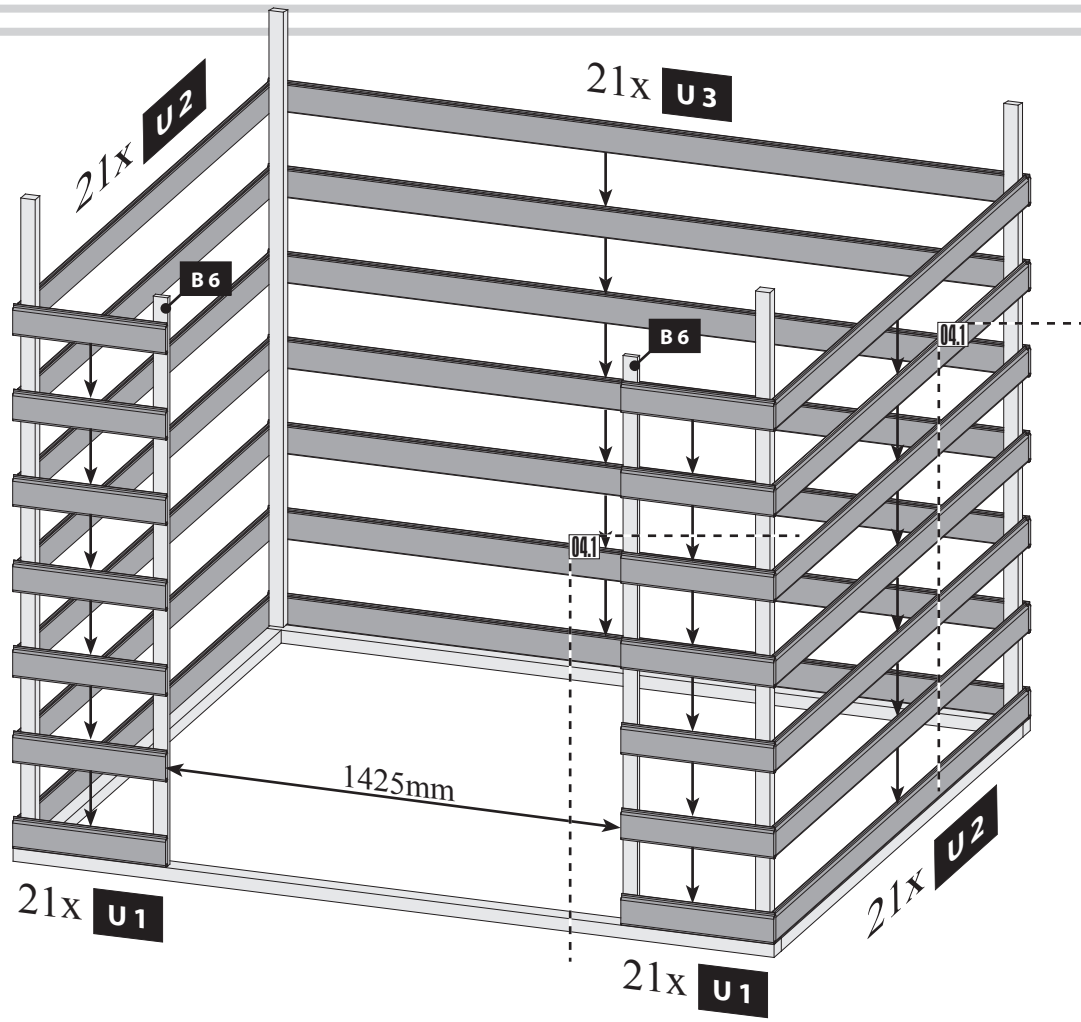

**04.1**

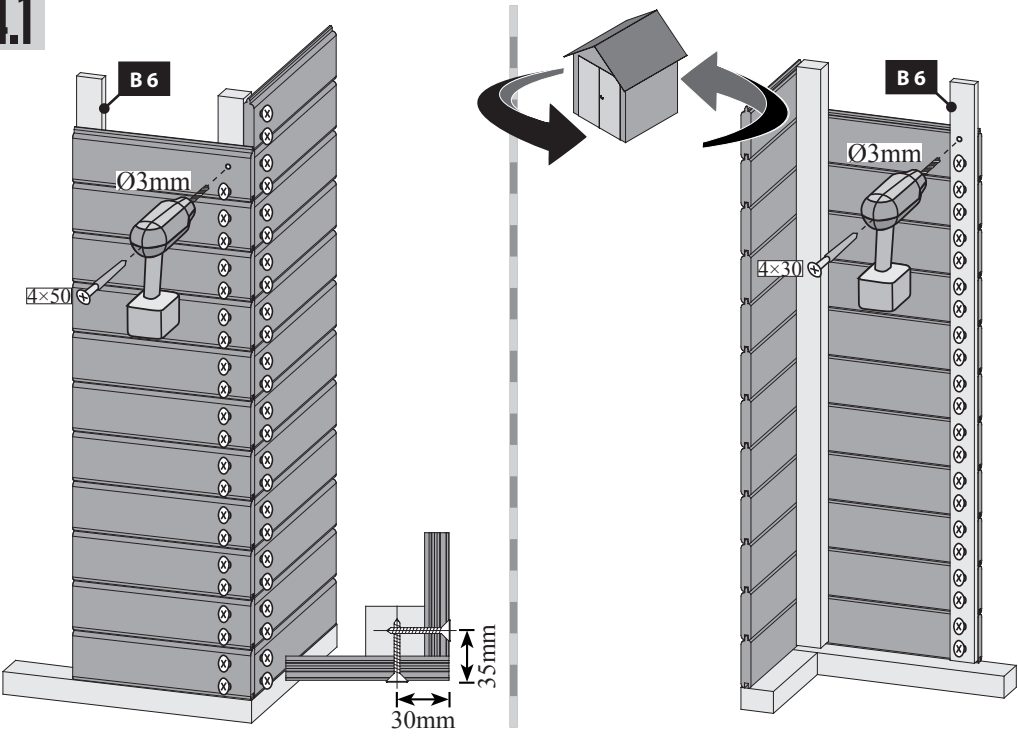

**04.2**

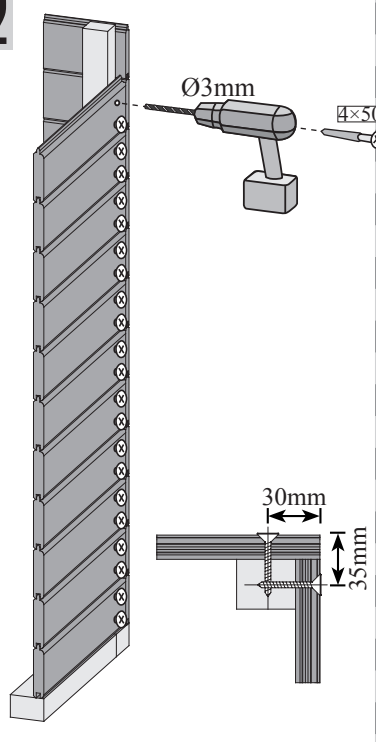

05 2x

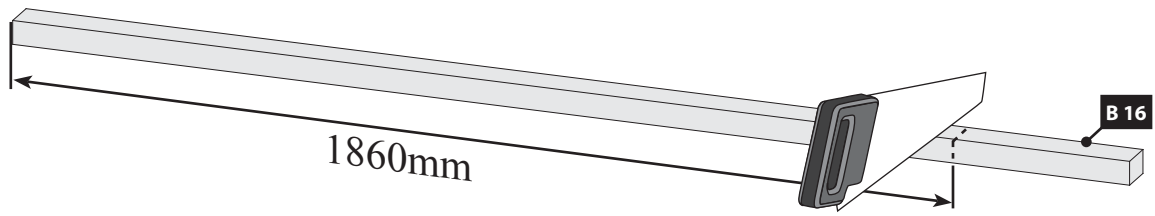

06

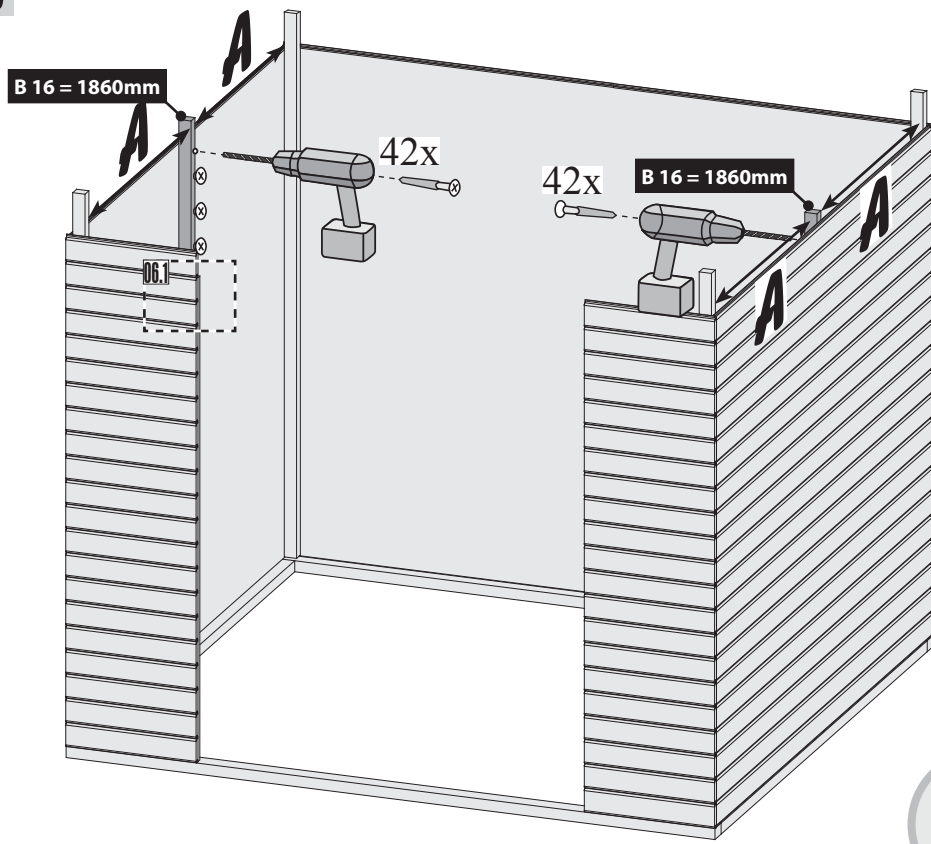

06.1

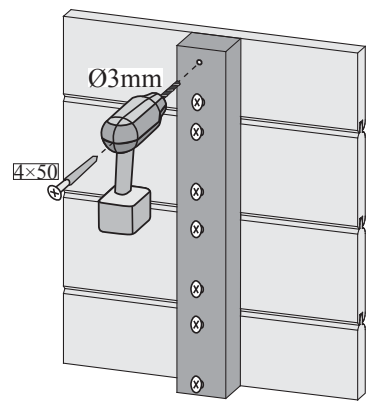
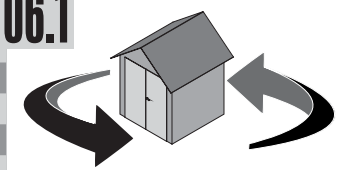

07

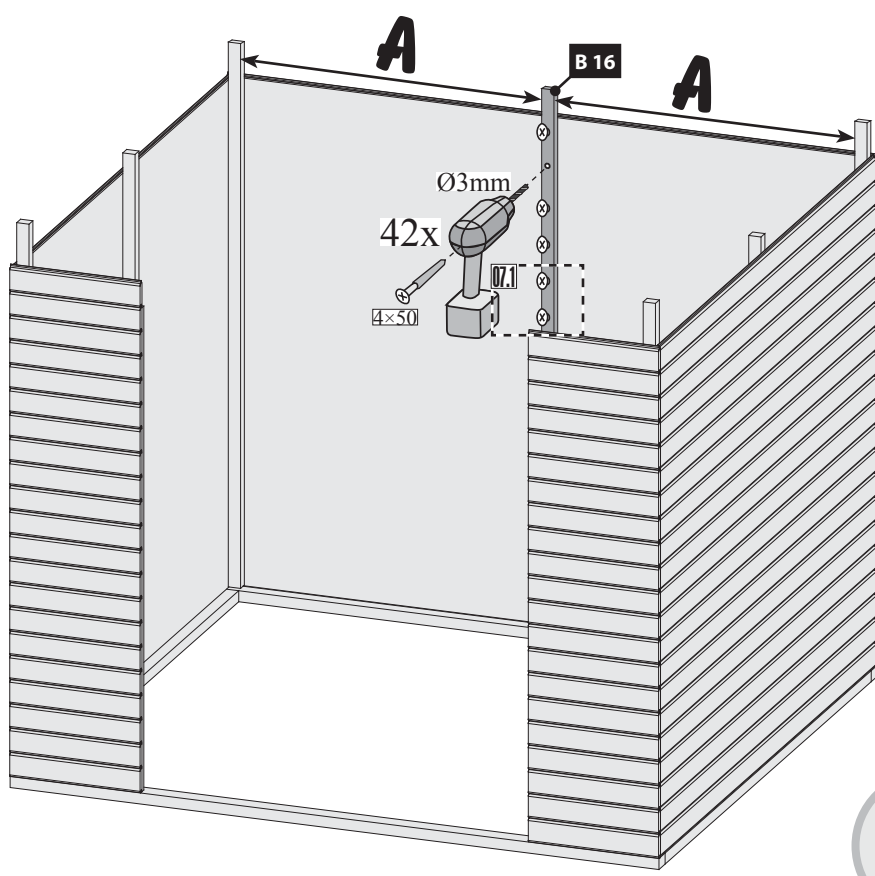

07.1

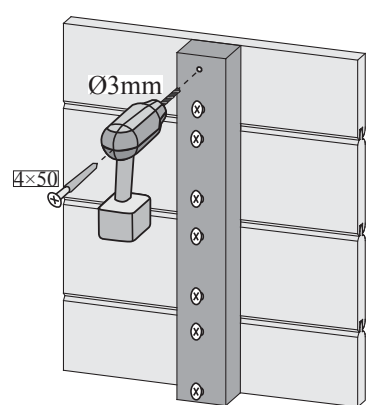

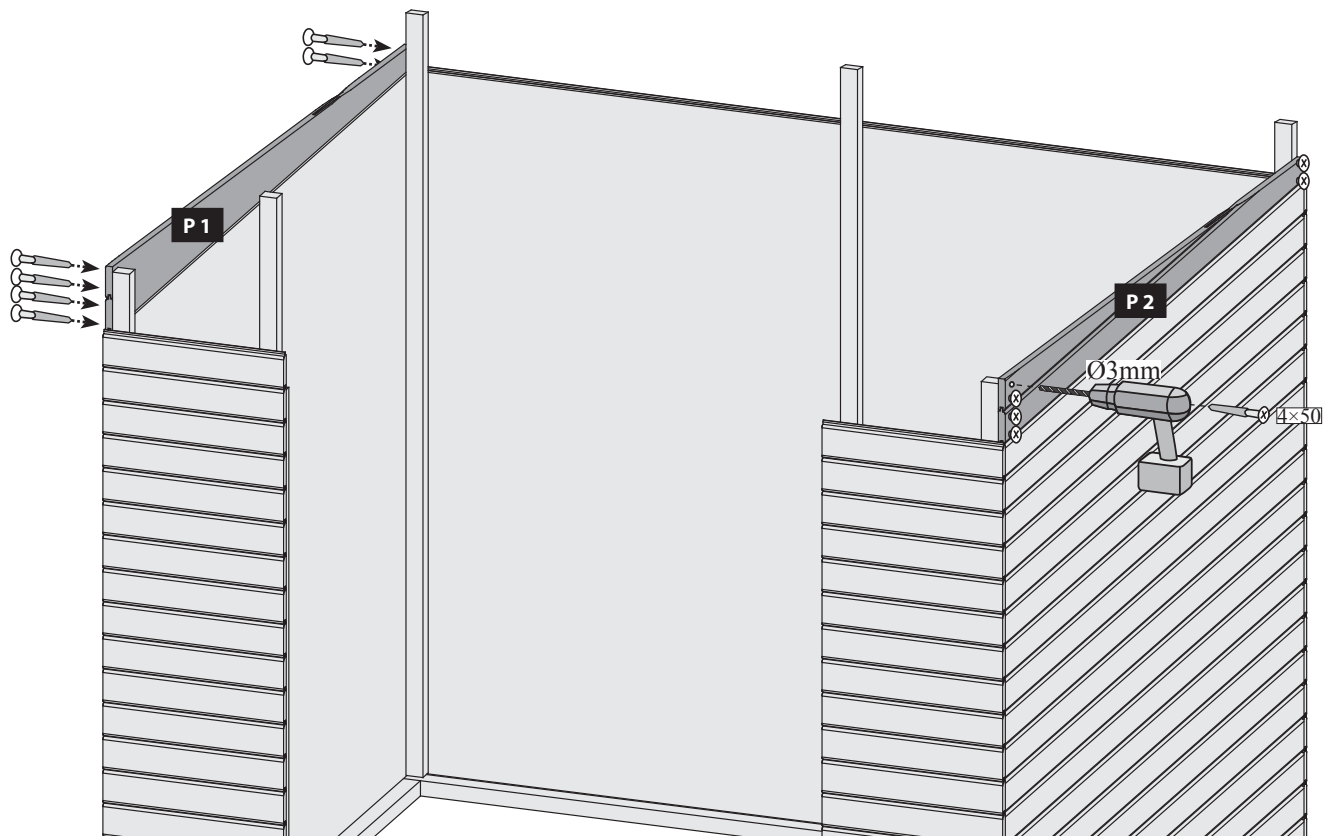

Bündig!  
 Affleurement!  
 Gelijk!  
 Aras!  
 Flush!  
 Combacia!  
 Flush!

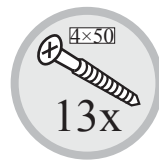
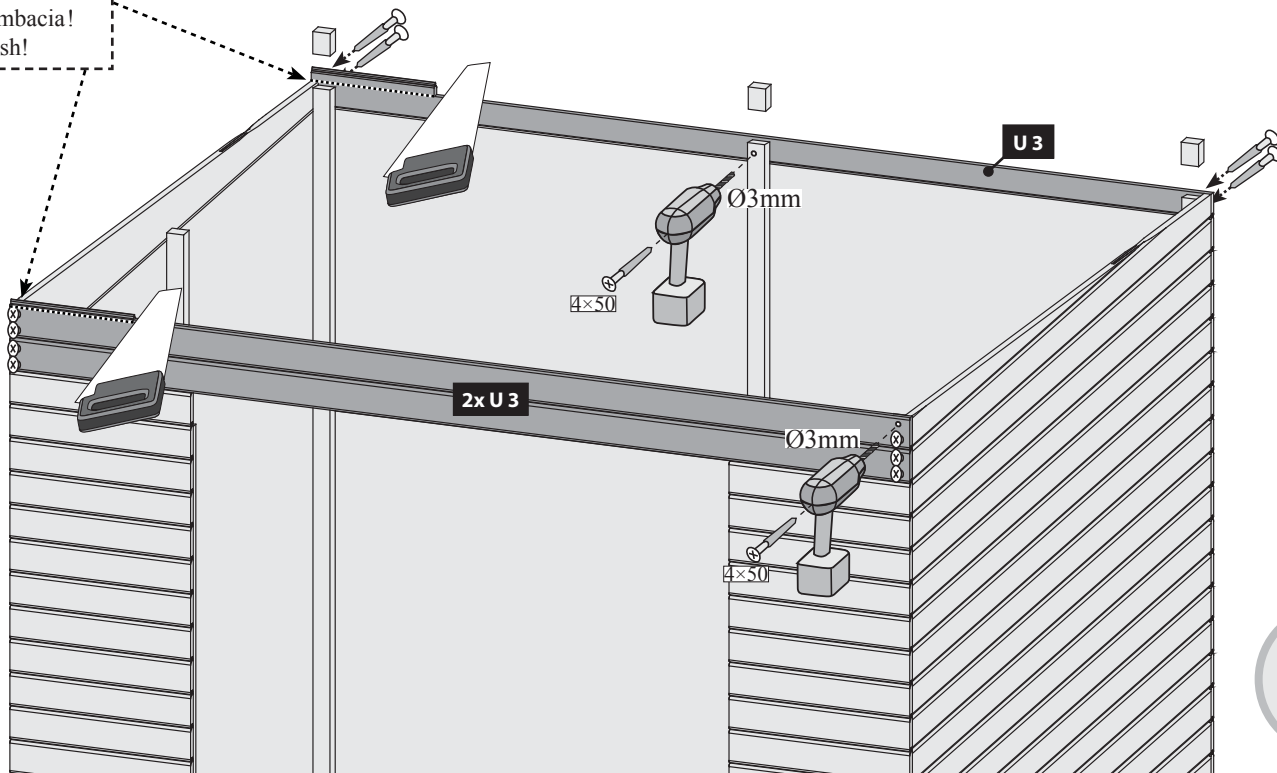

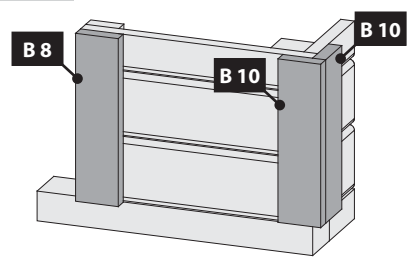
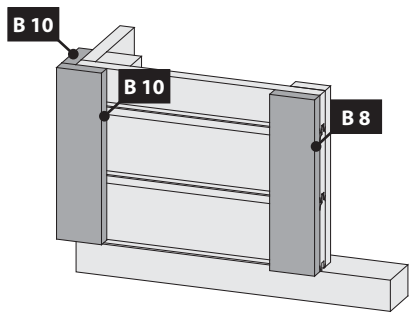
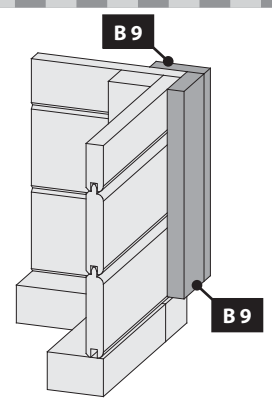
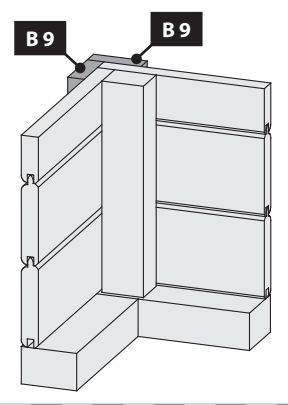
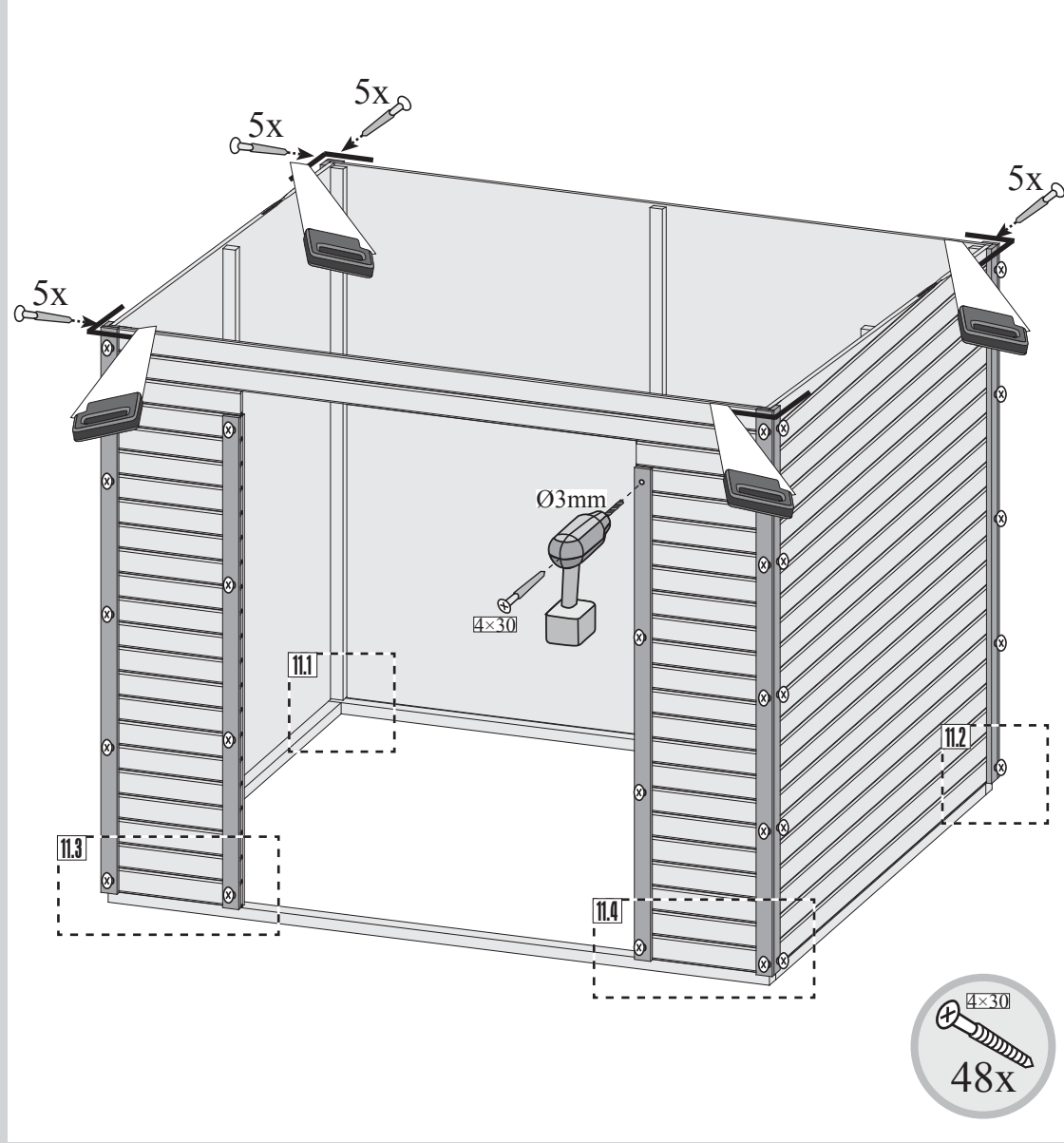
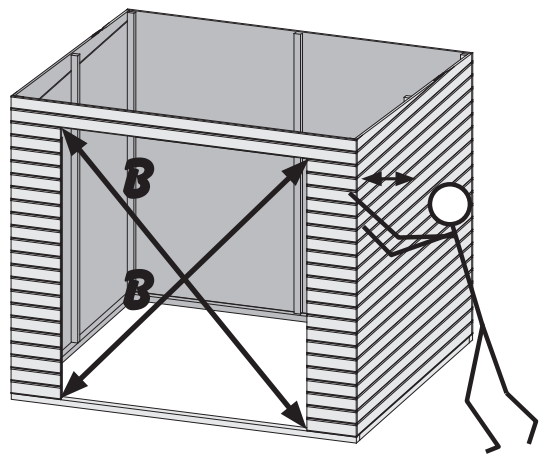
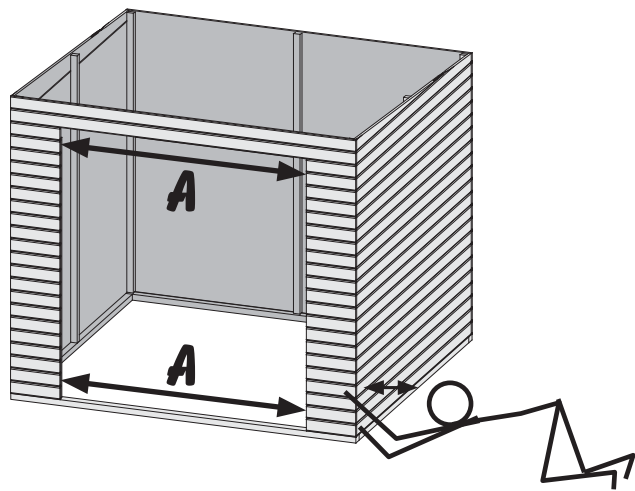



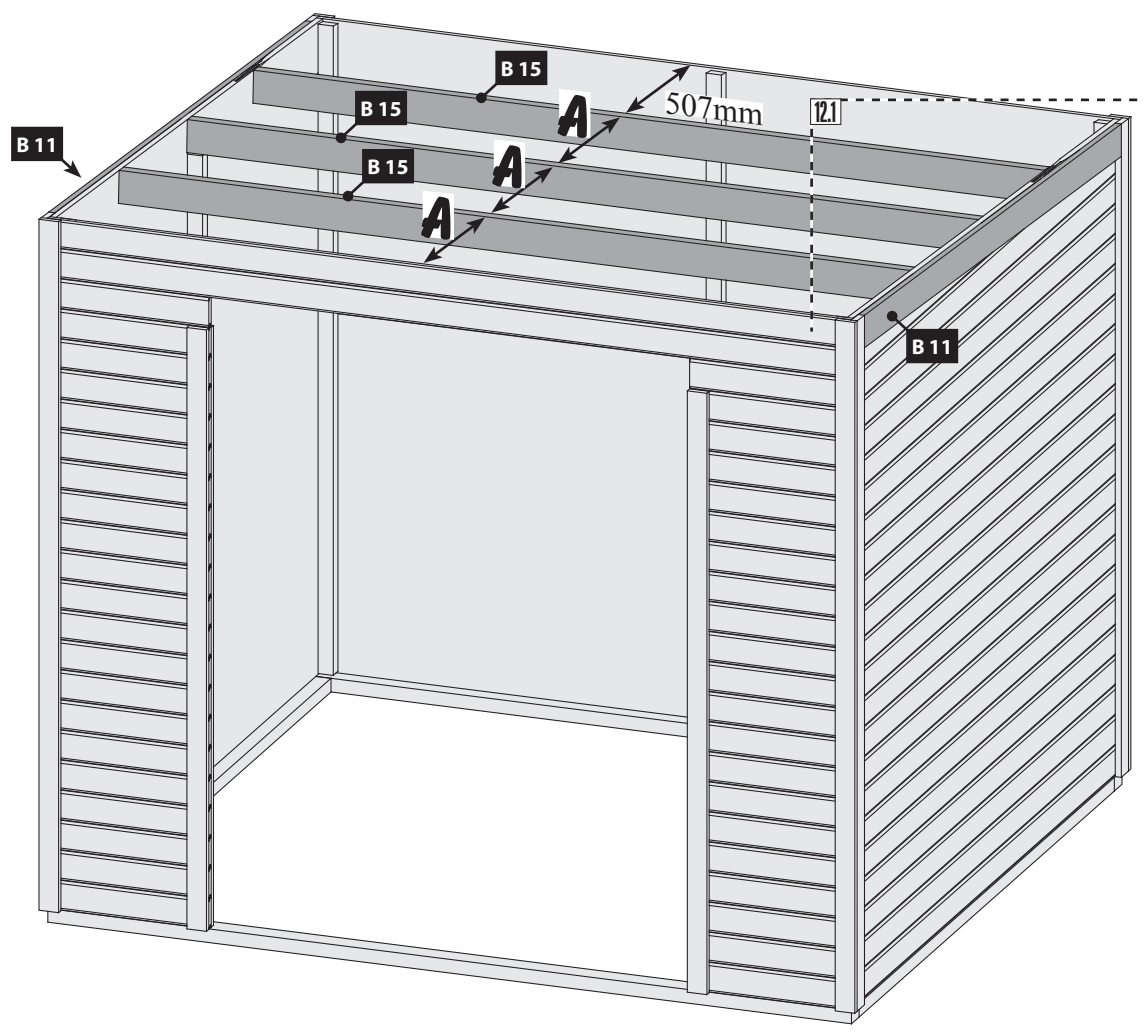

12.1-1

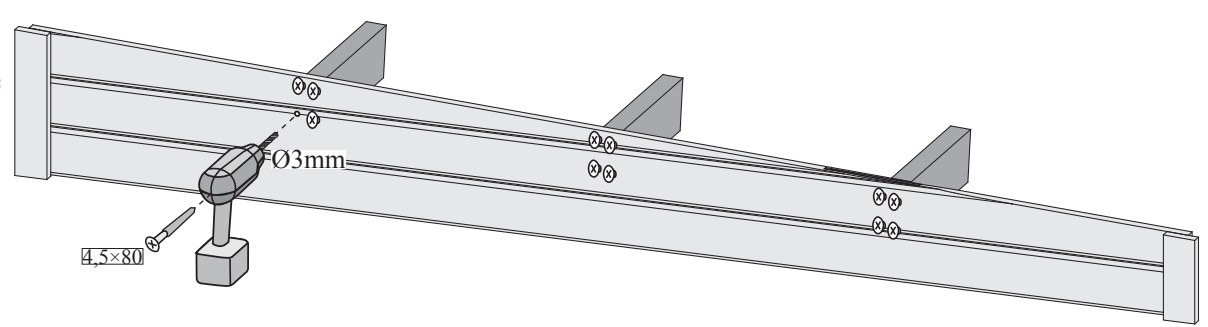
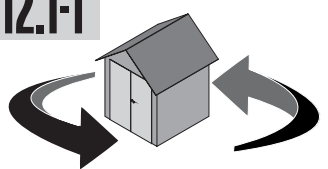

12.1-2

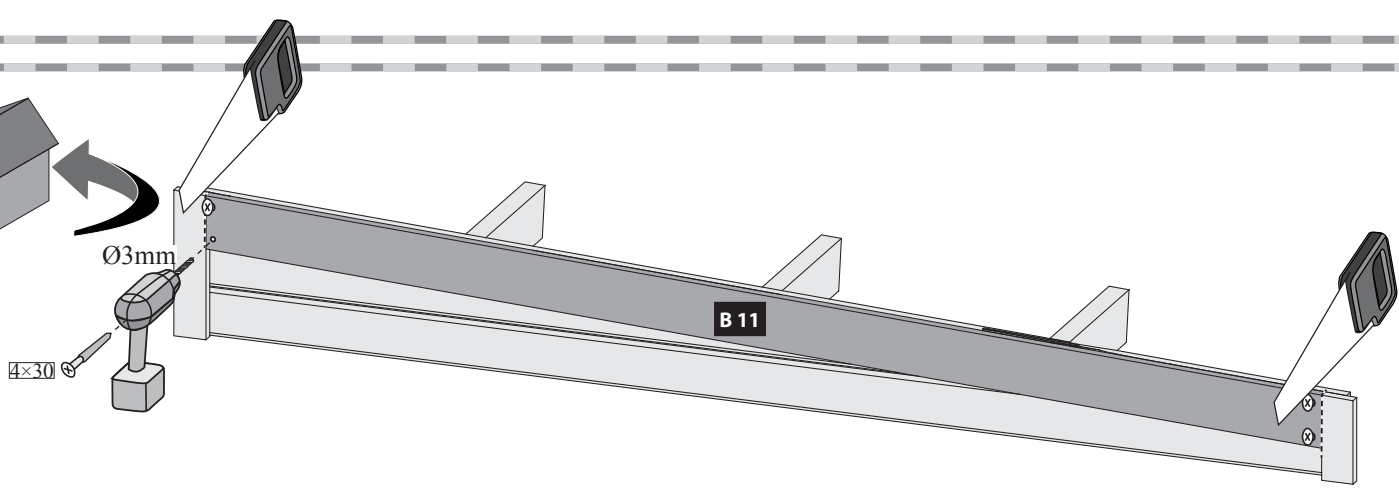
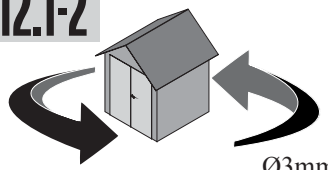

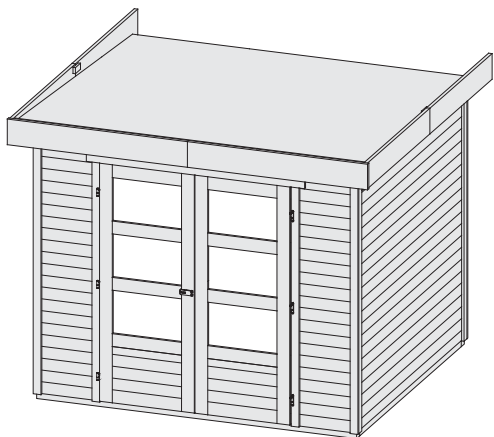

⇒ **13 A !**

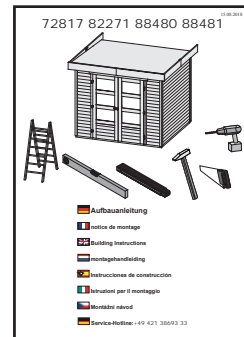

**14 + 15 + ...**

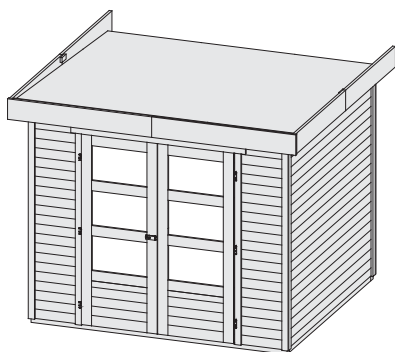

⇒ **13 B !**

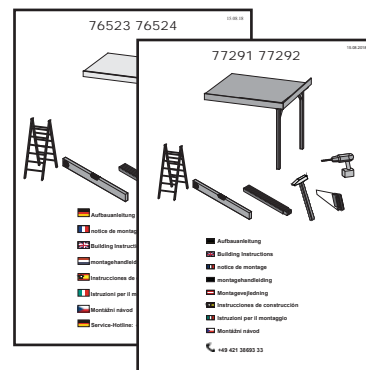

**01 + 02 + ...**

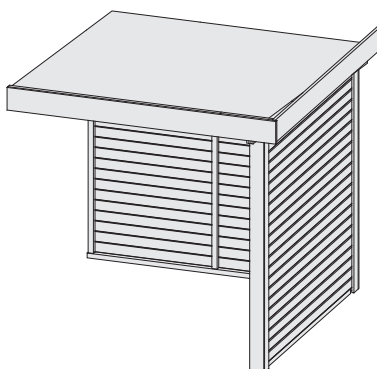
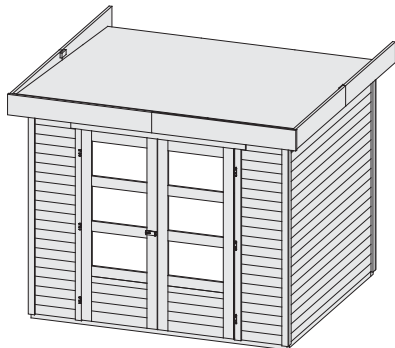

⇒ **13 B !**

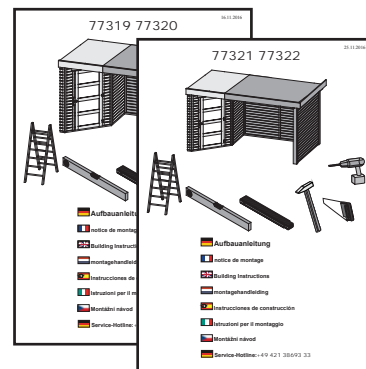

**01 + 02 + ...**

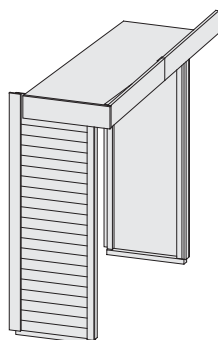
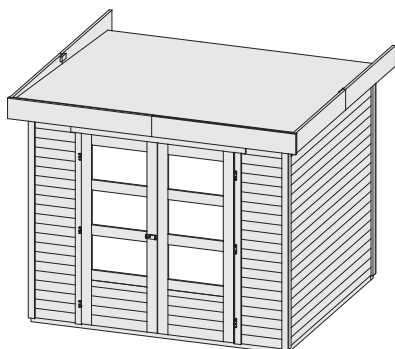

⇒ **13 C !**

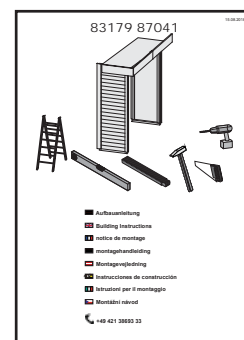

**01 + 02 + ...**

# 13 A

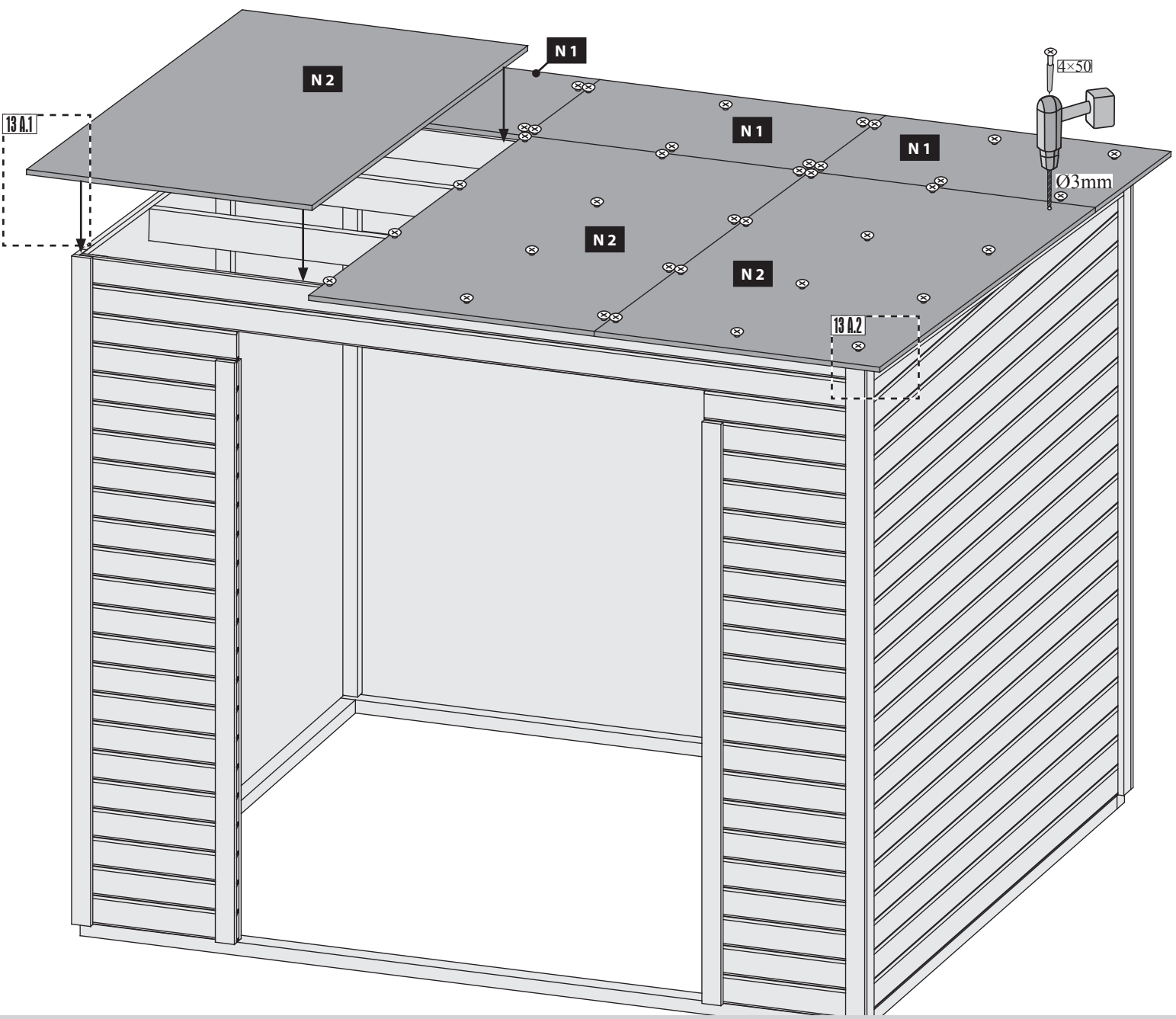
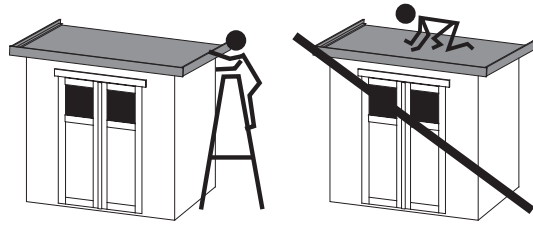

## 13 A.1

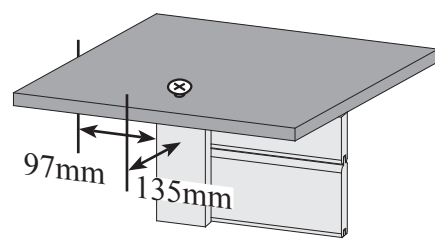

## 13 A.2

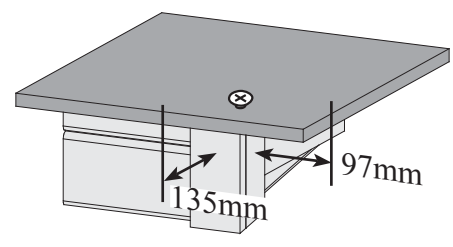

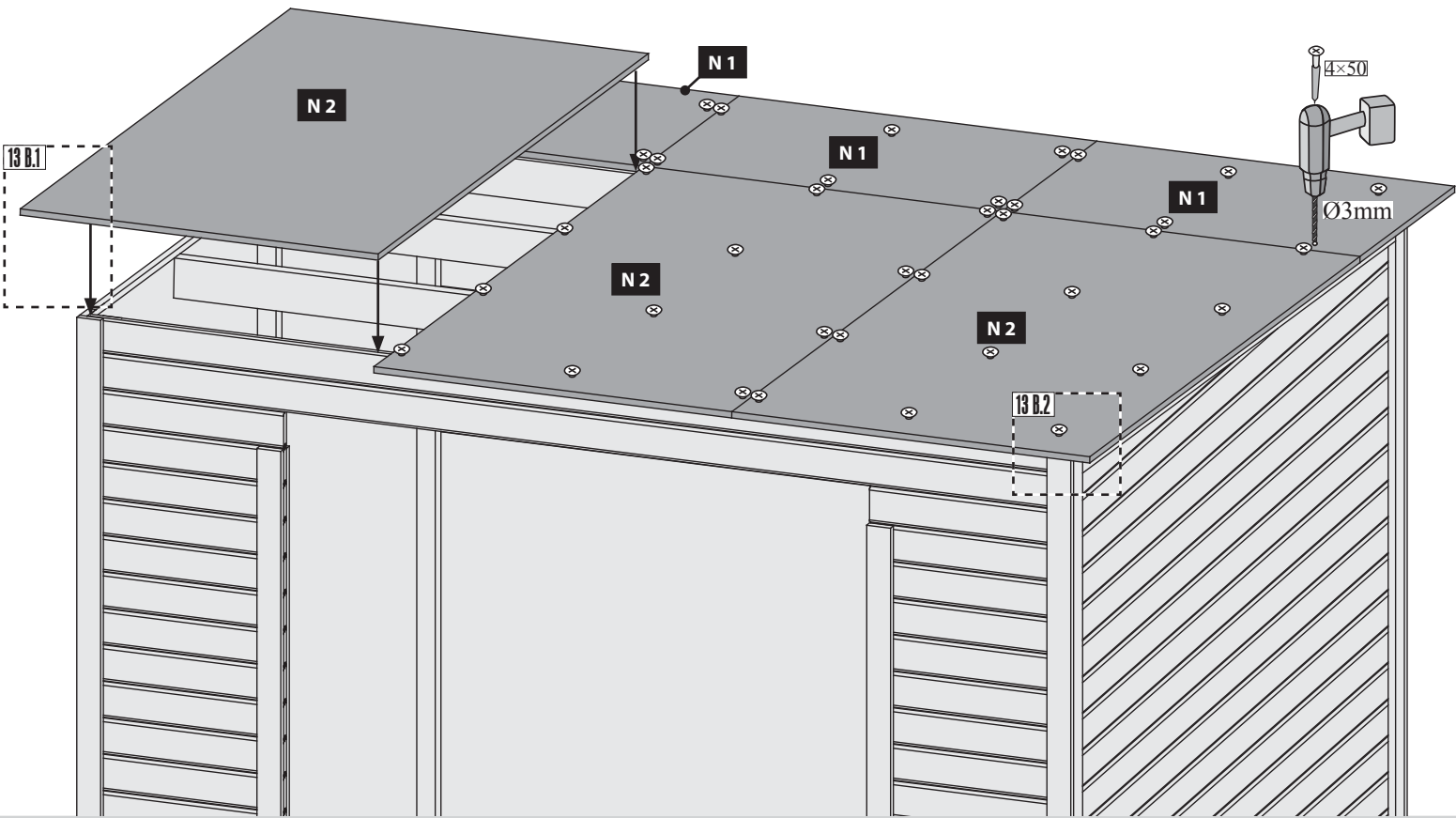
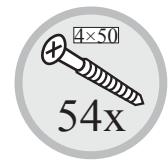
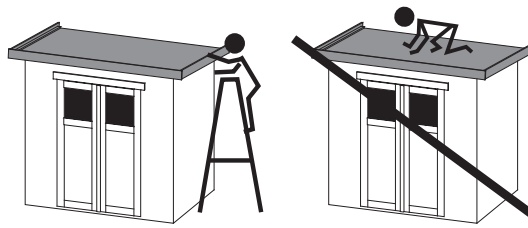

## 13 B.1

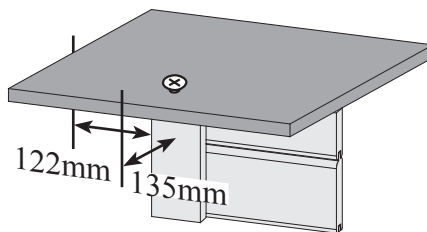

## 13 B.2

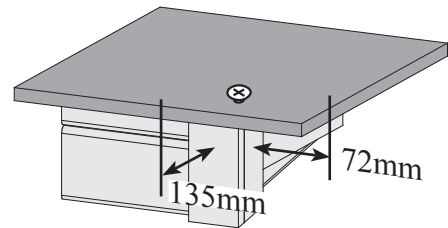

### Bei Anbaudach

**rechts** Dachüberstand Haus links = 122 mm / rechts = 72 mm  
**links** Dachüberstand Haus links = 72 mm / rechts = 122 mm

### With attached roof

**right** Roof overhang house left = 122 mm / right = 72 mm  
**left** Roof overhang house left = 72 mm / right = 122 mm

### Avec toit attaché

**droit** Débord de toit Maison gauche = 122 mm / droite = 72 mm  
**gauche** Débord de toit Maison gauche = 72 mm / droite = 122 mm

### Met aangehecht dak

**rechts** Dakoverstek House links = 122 mm / rechts = 72 mm  
**links** Dakoverstek House links = 72 mm / rechts = 122 mm

### Med vedhæftet tag

**Ved sidetag højre** Tagudhæng Hus venstre = 122 mm / højre = 72 mm  
**Ved sidetag venstre** Tagudhæng hus venstre = 72 mm / højre 122 mm

### Con techo adjunto

**derecho** Casa alero izquierda = 122 mm / derecha = 72 mm  
**izquierdo** Casa alero izquierda = 72 mm / derecha = 122 mm

### Quando si monta con il tetto

**destra** Tetto sbalzo lasciato casa = 122 mm / destra = 72 mm  
**sinistra** Tetto sbalzo lasciato casa = 72 mm / destra = 122 mm

### Pro montáž s tažnou střechou

**doprava** Přesah střechy domu vlevo = 122 mm / vpravo = 72 mm  
**levý** Přesah střechy domu vlevo = 72 mm / vpravo = 122 mm

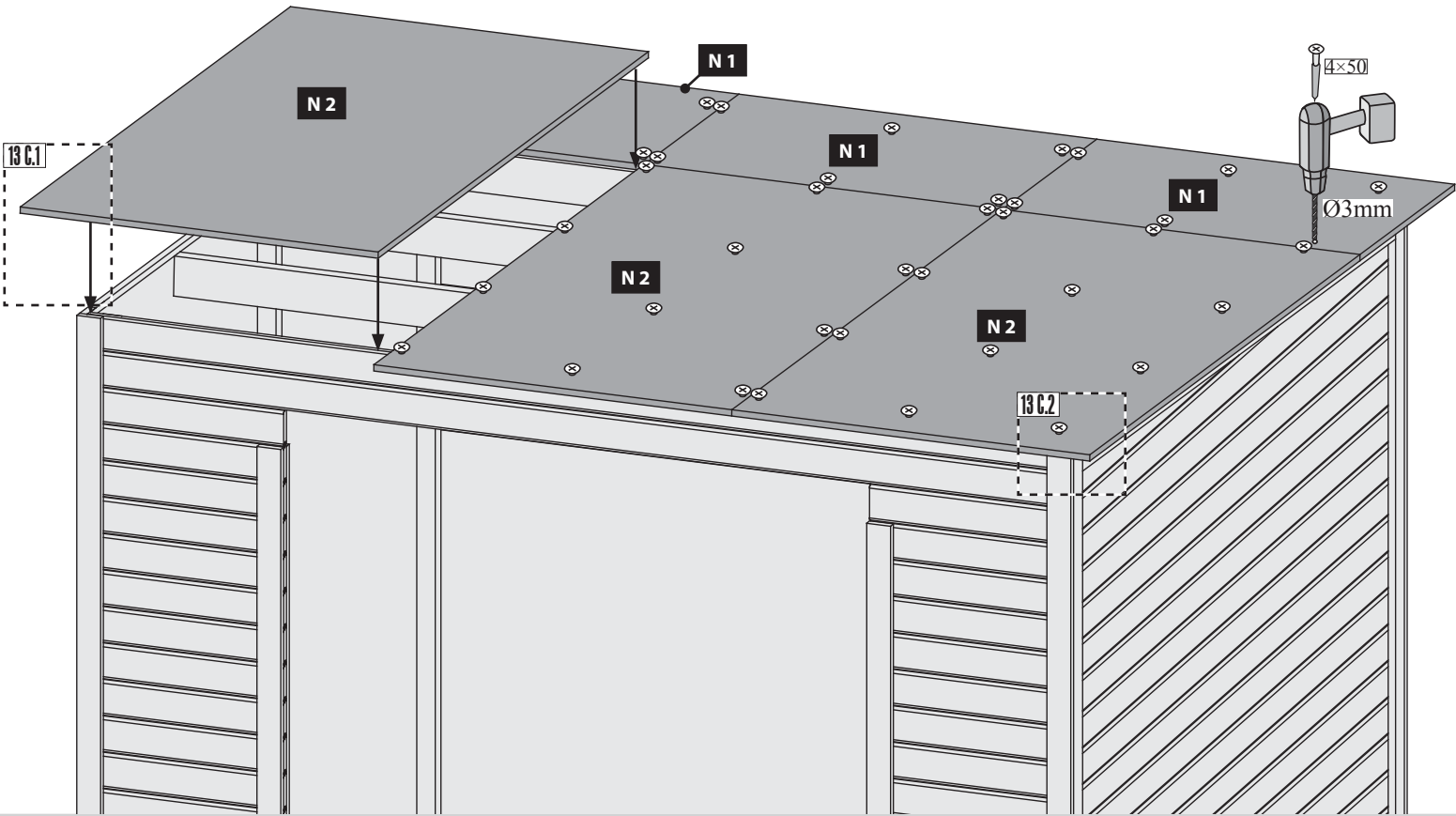
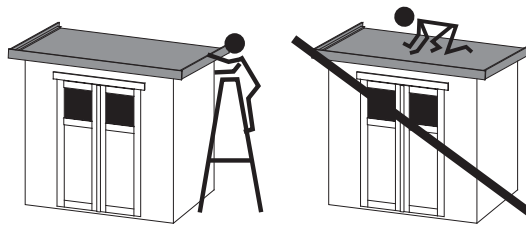

## 13 C.1

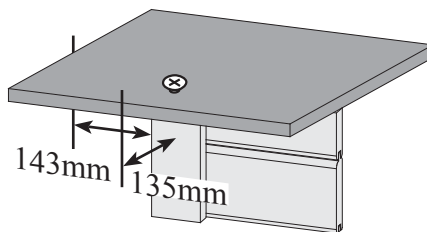

## 13 C.2

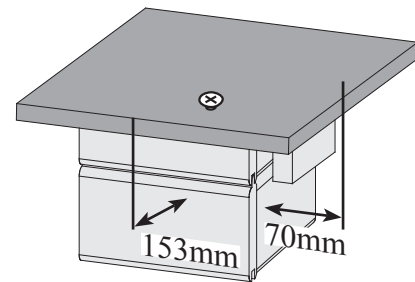

### Bei Anbaudach

**rechts** Dachüberstand Haus links = 143 mm / rechts = 70 mm  
**links** Dachüberstand Haus links = 70 mm / rechts = 143 mm

### With attached roof

**right** Roof overhang house left = 143 mm / right = 70 mm  
**left** Roof overhang house left = 70 mm / right = 143 mm

### Avec toit attaché

**droit** Débord de toit Maison gauche = 143 mm / droite = 70 mm  
**gauche** Débord de toit Maison gauche = 70 mm / droite = 143 mm

### Met aangehecht dak

**rechts** Dakoverstek House links = 143 mm / rechts = 70 mm  
**links** Dakoverstek House links = 70 mm / rechts = 143 mm

### Med vedhæftet tag

**Ved sidetag højre** Tagudhæng Hus venstre = 143 mm / højre = 70 mm  
**Ved sidetag venstre** Tagudhæng hus venstre = 70 mm / højre 143 mm

### Con techo adjunto

**derecho** Casa alero izquierda = 143 mm / derecha = 70 mm  
**izquierdo** Casa alero izquierda = 70 mm / derecha = 143 mm

### Quando si monta con il tetto

**destra** Tetto sbalzo lasciato casa = 143 mm / destra = 70 mm  
**sinistra** Tetto sbalzo lasciato casa = 70 mm / destra = 143 mm

### Pro montáž s tažnou střechou

**doprava** Přesah střechy domu vlevo = 143 mm / vpravo = 70 mm  
**levý** Přesah střechy domu vlevo = 70 mm / vpravo = 143 mm

14 2x

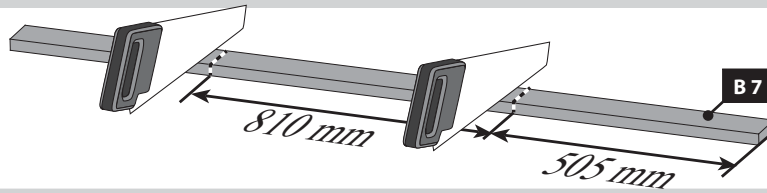

15

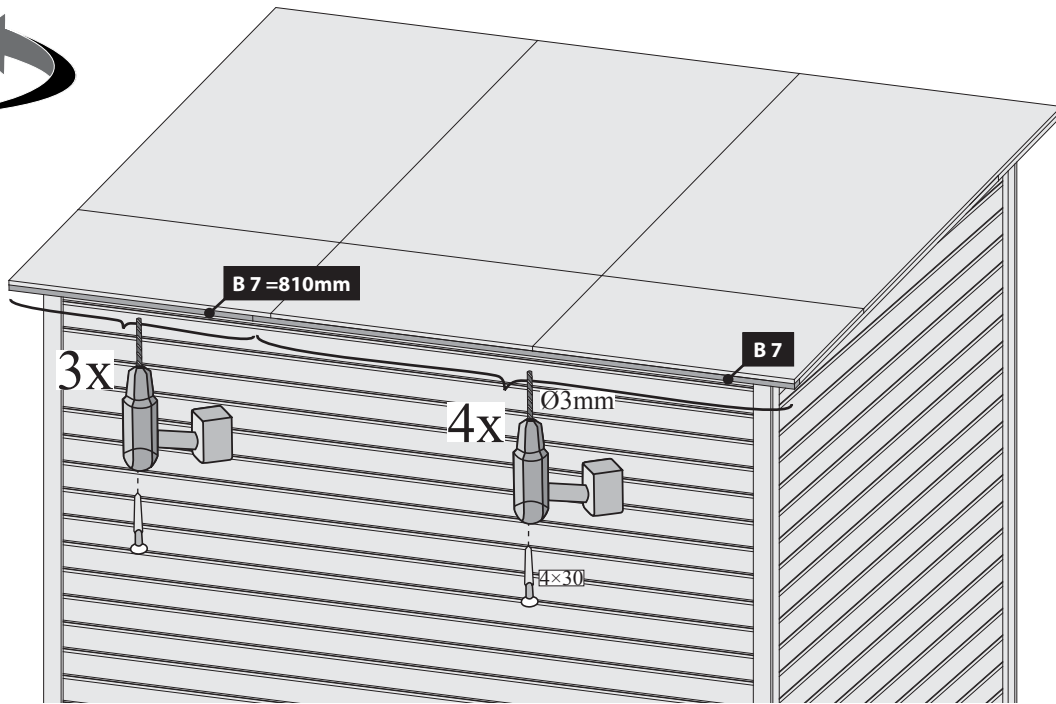
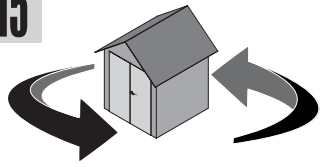



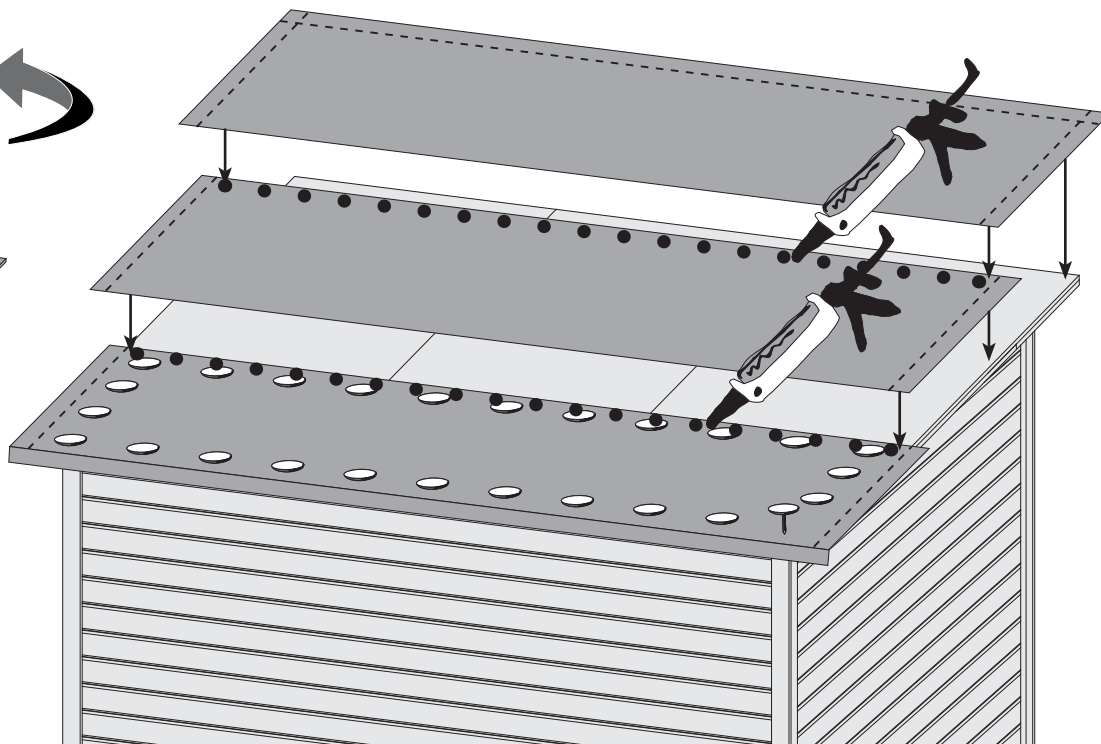
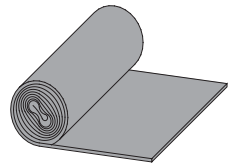
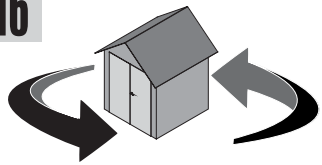

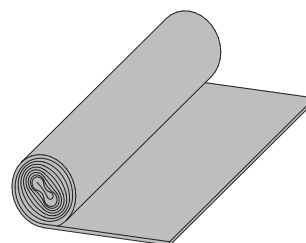
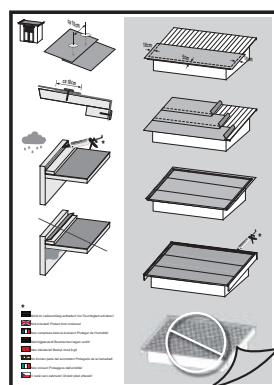

16



-  Kleber
-  Colle
-  Glue
-  Lijm
-  Pegamento
-  Colla
-  Lepek



-  Nicht im Lieferumfang enthalten
-  Niet bijgeleverd
-  Not included
-  Non comprises dans la livraison
-  No forman parte del suministro
-  Non incluso
-  V ceně není zahrnuto

 Montage Bitumendachbelag

 Montage de toiture en bitume

 Montage bitumen underpap

 Copertura bituminosa

 Roofing felt installation

 Montage dakvilt

 Montaje de tela asfáltica

 montáž střešní krytiny

### **Achtung, dies ist nur ein Verlegebeispiel!**

Der Bitumendachbelag dient zur Ersteindeckung und sollte nach 2 Monaten durch ein eigenes Produkt ergänzt werden. Die Anzahl der Bahnen richten sich nach Ihrer Hausgröße. Verbindungen zwischen den Bahnen sind mit einer Überlappung von ca. 10 cm auszuführen. Das Dach ist nicht begehbar. Die Konstruktion ist für eine Gesamtbelastung (Schnee, Wind) und nicht für eine Punktbelastung ausgelegt. Zur Montage empfehlen wir eine bauseitige Abstützung des Daches von unten. Die Abdichtung der Dachflächen zu angrenzenden Bauteilen mit Bitumendichtmasse ist bauseits zu lösen! Sofern es sich um ein Haus mit Satteldach handelt, sollte bei der Verwendung von Dachschindeln keine Voreindeckung mit Dachpappe vorgenommen werden. Hier sollte lediglich an den beiden Traufseiten ein 20 cm breiter Streifen mit Überstand angebracht werden. Bei Häusern mit einem Tonnendach, verlegen Sie bitte einen Bitumenbelag unter die Schindeln. Bei einem Flachdach ist die Verlegung von Dachschindeln nicht möglich!

### **Note! This description is only an example!**

The bitumen roofing is used for initial cover and should be supplemented by a separate product according to customers choice after two months. The number of bitumen strips to be used depends on your actual house size. When joining rolls of roofing felt end to end, the overlap must be approximately 10cm. The roof is not safe to walk on. The roof is designed for a total load (snow, wind) and not for a point load. We recommend you to always support the roof from below during installation. The sealing of the roof surfaces to adjacent components with bitumen sealant has to be effected by the customer! If it is a saddle-roofed house, do not use roofing tiles for roofing. In this case, a 20 cm wide strip of bitumen with overhang should be installed on both sides of the eaves. For houses with a tonne roof, please install a bitumen roofing under the shingles. In the case of a flat roof the laying of roof shingles is not possible!

### **Attention, il s'agit uniquement d'un exemple de pose!**

La revêtement se comprend comme dotation initiale. Il est donc recommandé de le compléter par un produit de votre choix après 2 mois. Le nombre de bandes de bitume utilisés dépend de la dimension de la maison. La jointure des bandes de bitume doit être réalisée avec un chevauchement de 10 cm. Ne pas marcher sur le toit! La construction est appropriée pour une charge totale (neige, vent) et ne pas une charge ponctuelle sur un point précis. Lors du montage, il vous est recommandé de soutenir le toit d'en dessous. L'imperméabilisation des surfaces de toit aux composants adjacents avec un mastic de bitume doit être effectuée par le client! Lorsque vous utilisez des bardeaux pour couvrir une maison avec un toit à deux versants, ne jamais utiliser toiture en bitume ci-dessous. Pour les maisons avec toit en berceau, poser du carton bitumé sous les bardeaux. Pour les maisons de toit plat de la pose de bardeaux de toiture n'est pas possible!

### **Let op, dit is slechts een montagevoorbeeld!**

De bitumen dakbedekking wordt gebruikt voor initiële en moet worden aangevuld met een afzonderlijke product na 2 maanden. Het aantal dakviltbanen is afhankelijk van de grootte van uw huis. Verbindingen tussen de stroken uit te voeren met een overlapping van ongeveer 10 cm. Het dak is niet beloopbaar. De constructie is ontworpen voor een totaalbelasting (sneeuw, wind) en niet voor een puntbelasting. Voor de montage adviseren we te voorzien in een zelf aan te brengen steun voor het dak van onderen. De afdichting van de dakoppervlakken van aangrenzende componenten met bitumen afdichtmiddel op te lossen door de klant! Als het gaat om huis met een zadeldak, mag geen Voreindeckung worden gemaakt met dakleer in het gebruik van dakbedekking gordelroos. Hier, moet alleen de twee dakrand zijden een 20cm brede strook dakleer aan te leggen met een overstek. Voor huizen met een dak vat installeer dan een dakleer onder de gordelroos. Met een plat dak leggen shingles is niet mogelijk!

### **Bemærk, dette er kun et monteringsksempel!**

Den inddækning tjener kun til midlertidig inddækning og skal senest efter 2 måneder erstattes med et hertil egnet produkt. Antallet af påkrævede ruller af tagbeklædning afhænger af husets faktiske størrelse. Ved sammenføjning af tagdækning ruller ende til ende, skal overlappningen være 10 cm. Når du kun bruger 4 baner af tagpap, skal du altid dække den vandrette kantbjælke med rullerne fra begge sider. Taget er ikke sikkert at gå på. Taget er designet til en total belastning (sne, vind) og ikke for en punktbelastning. Vi anbefaler at du altid støtter taget nedenunder under installationen. Tætningen af tagfladerne til vindbrættet i forenderne skal løses af kunden! Når du bruger tagshingles til at inddække et hus med gavtag, skal du altid bruge underpap tagbeklædningen. Her lægges et 20 cm bredt bånd af tagbeklædning med overlæg på begge sider. Monter altid underpap tagbeklædningen under tagshingles til huse med et buet tag. Ved fladt tag kan tagshingles ikke anvendes!

### **Cuidado, éste es sólo un ejemplo de instalación!**

La cubierta de betún se utiliza para inicial y debe complementarse con un producto separado después de 2 meses. La cantidad de tiras de tela asfáltica depende del tamaño de su caseta. Las juntas de tela en una tira se realizan solapando la tela asfáltica 10 cm. El techo no es transitable. La construcción está preparada para cargas totales (nieve, viento) y no para cargas puntuales. Para el montaje se recomienda apuntalar el techo por debajo. A menos que haya una casa de techo a dos aguas, sin Voreindeckung debe hacerse con tela asfáltica en el uso de tejas para techos. En este caso, sólo los dos aleros partes deben ser de una amplia franja de 20 cm de tela asfáltica que deben colocarse con un voladizo. Para las casas con el techo abovedado y por favor, instale un techo sintió debajo de las tejas. Con un techo plano por el que las tejas no es posible!

### **Attenzione, questo è solo un esempio di posa!**

La copertura bitume è utilizzato per iniziale e deve essere completato da un prodotto separato dopo 2 mesi. La quantità dei rulli di cartone catramato dipende dalle dimensioni della casa. Il concatenamento tra i nastri deve essere effettuata con una sovrapposizione di circa 10 cm. Non salire sul tetto. La costruzione è progettata per un carico diffuso (neve, vento) e non per una concentrazione puntuale del peso. Per il montaggio si consiglia un supporto del tetto con una costruzione posta sotto di esso. Se si dispone di una casa con un tetto a capanna e si desidera utilizzare tegole di copertura, deve essere posato senza fogli di bitume. Qui, un largo 20 cm striscia di bitume deve essere montato esclusivamente ad entrambi i lati della grondaia sporgente 20 cm. Per le case con fogli di bitume per tetti a botte sotto il fuoco di Sant'Antonio da installare. Si prega di non utilizzare il fuoco di Sant'Antonio Dackdeckung con un tetto piatto.

### **Pozor, toto je jen příklad, kterým!**

Bitumen se používá pro počáteční a by měl být doplněn samostatný produkt po 2 měsících.

Počet Dachpappbahnen závisí na velikosti domu. Spojení mezi asfaltem pásu má být provedena s přesahem asi 10 cm. Při použití pouze čtyři běhy ne Firstbahn použití, boční panely s ležel přes hřeben. Střecha není přístupný. Konstrukce je (sníh, vítr) a není určen pro bodové zatížení na celkové zatížení. Pro montáž doporučujeme znovu podporu na místě střechy zespodu. Utěsnění střešních oblastí do podhledů na čelních plochách je na místě řešit! Máte-li dům se sedlovou střechou, je třeba žádné Asfaltové pásy umístěny pod šindele. Zde je 20 cm široký pás střešní plst' je pouze na obou stranách okapového se supernatantem odloženou. Pro rodinné domy s valenou střechou prosím ležel lepenkový pod šindelem. Pro ploché střechy domů pokládka střešních šindelů není možné!

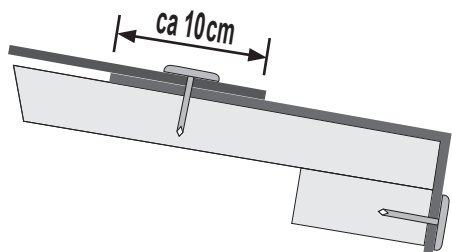
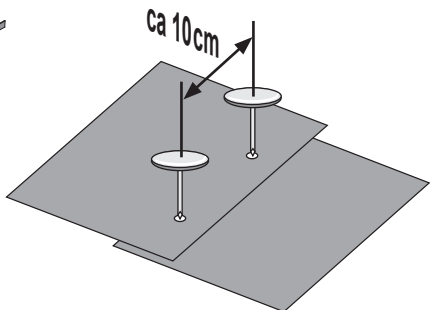
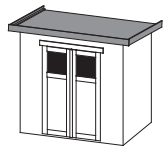

- \*  Nicht im Lieferumfang enthalten
-  Niet bijgeleverd
-  Not included
-  Non comprises dans la livraison
-  No forman parte del suministro
-  Non incluso
-  V ceně není zahrnuto

-  Vor Feuchtigkeit schützen!
-  Beschermen tegen vocht!
-  Protect from moisture!
-  Protéger de l'humidité!
-  Protegerlo de la humedad!
-  Proteggere dall'umidità!
-  Chránit před vlhkostí!

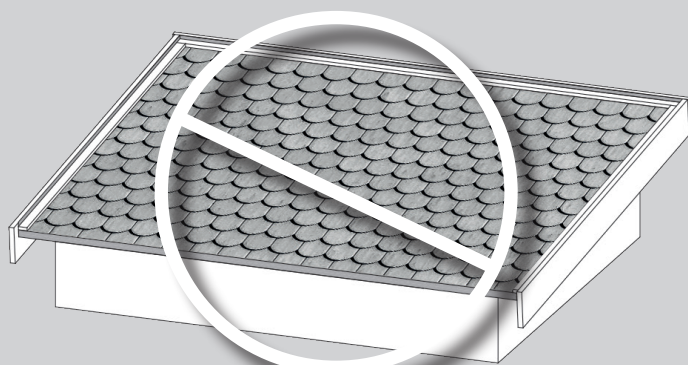
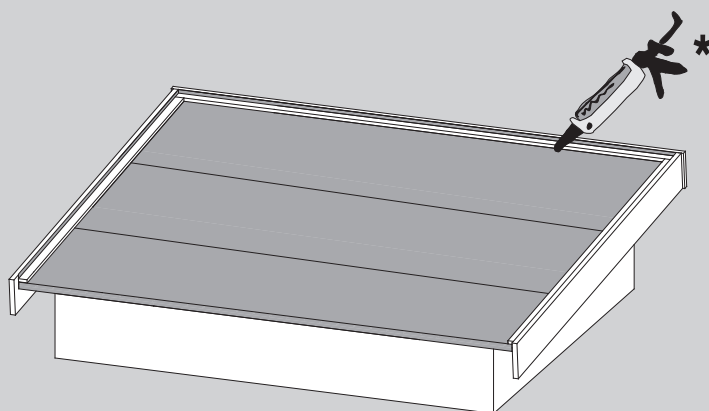
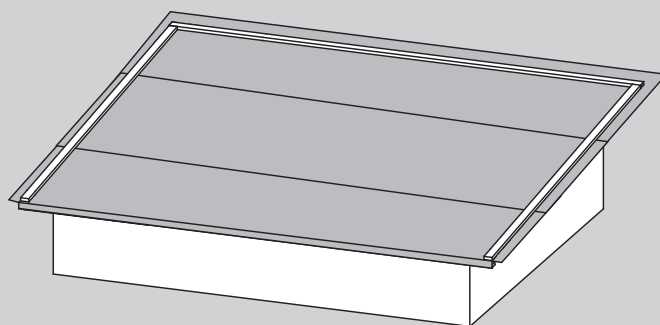
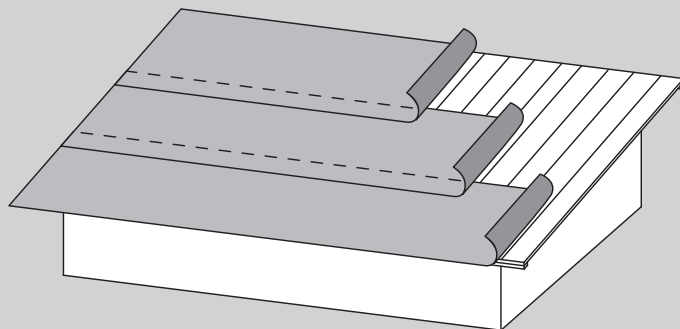
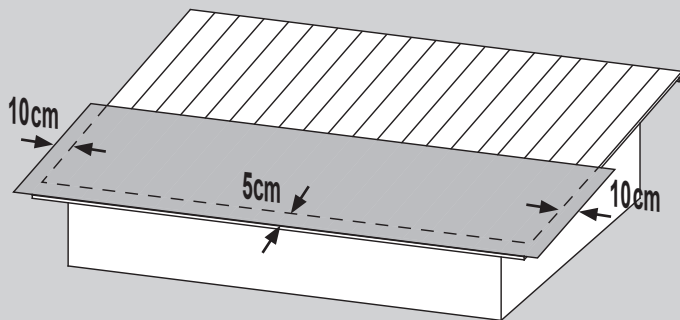



17

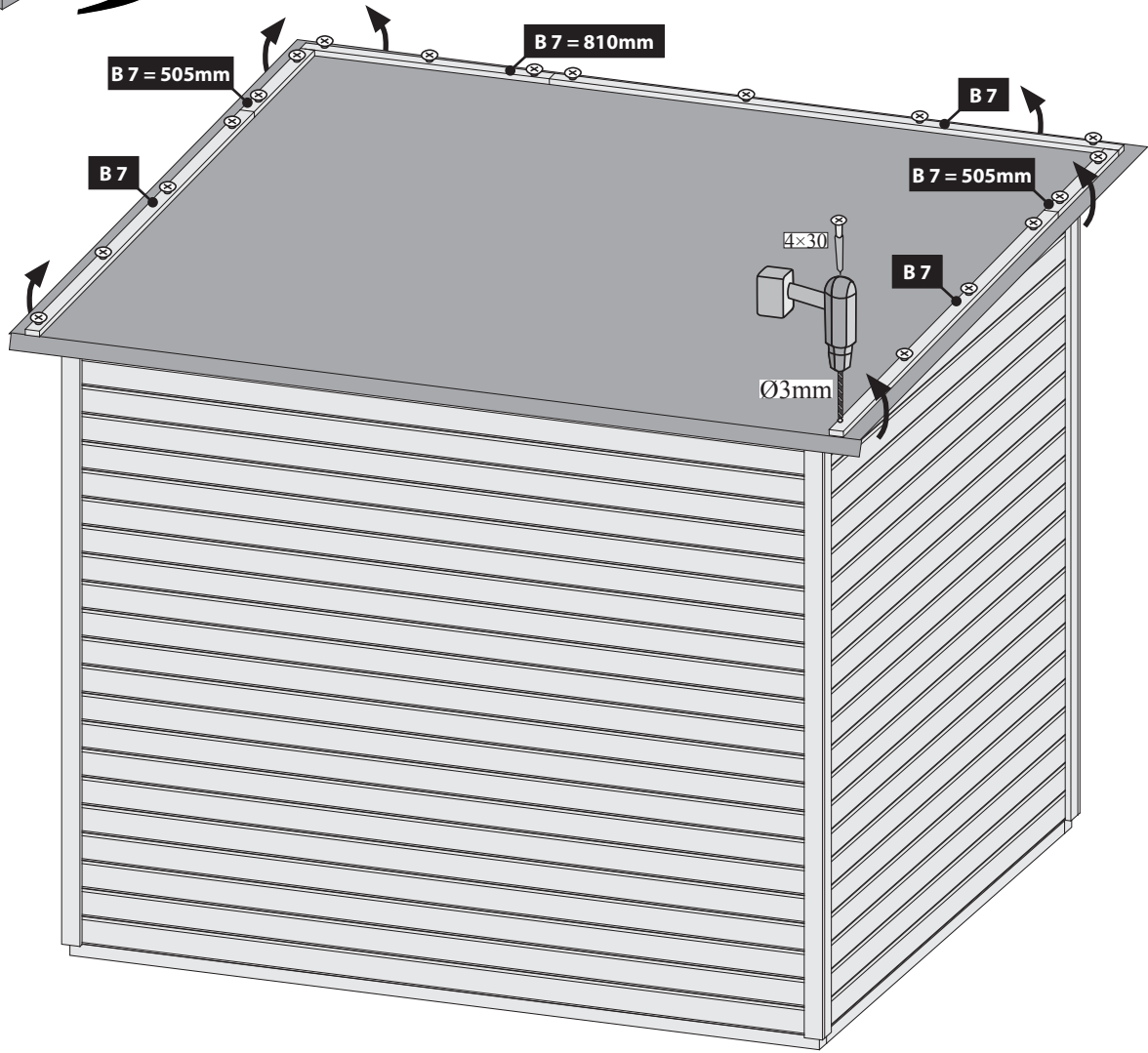
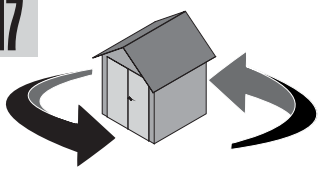

18 2x

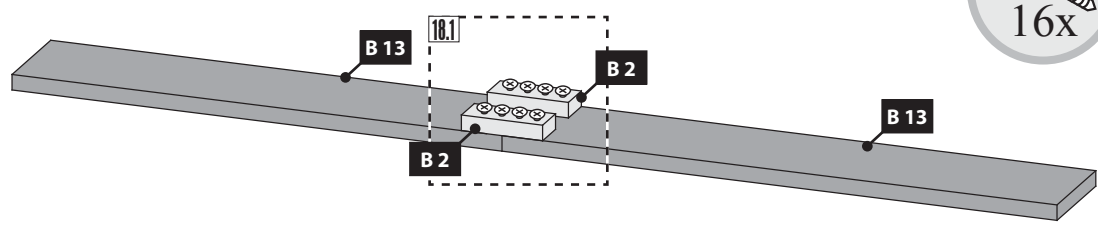

18.1

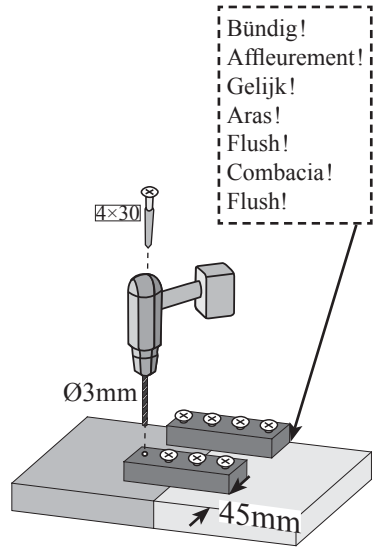

19 1x

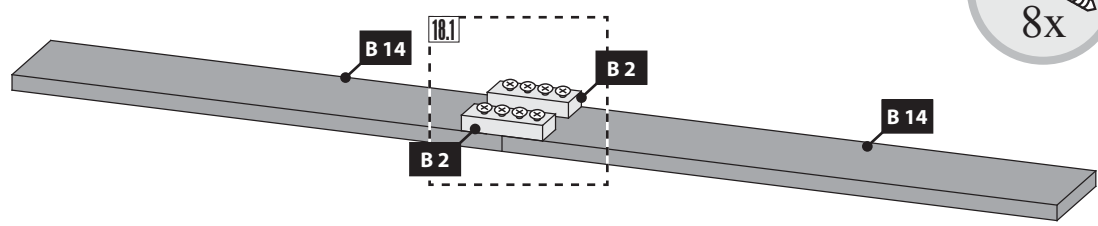

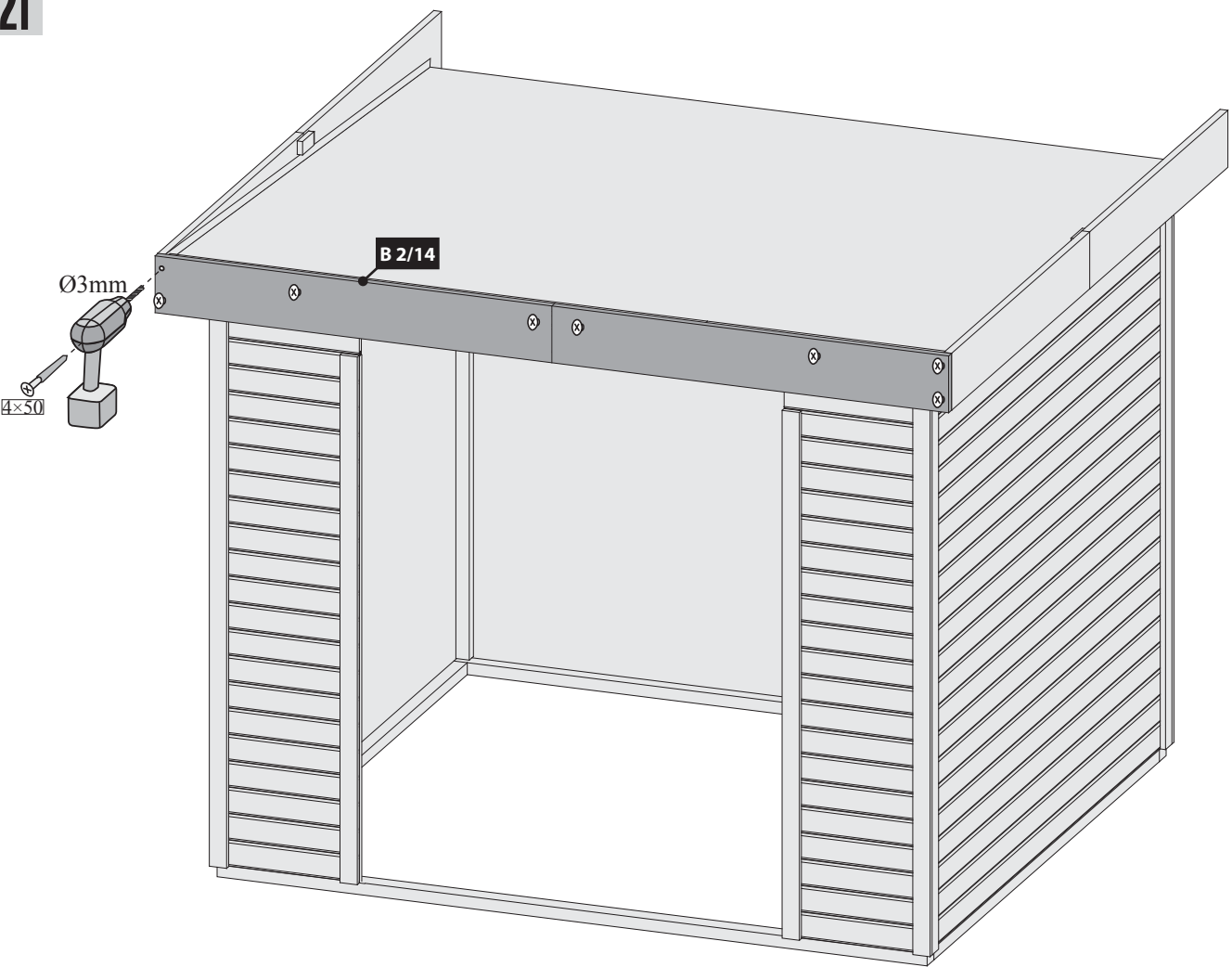
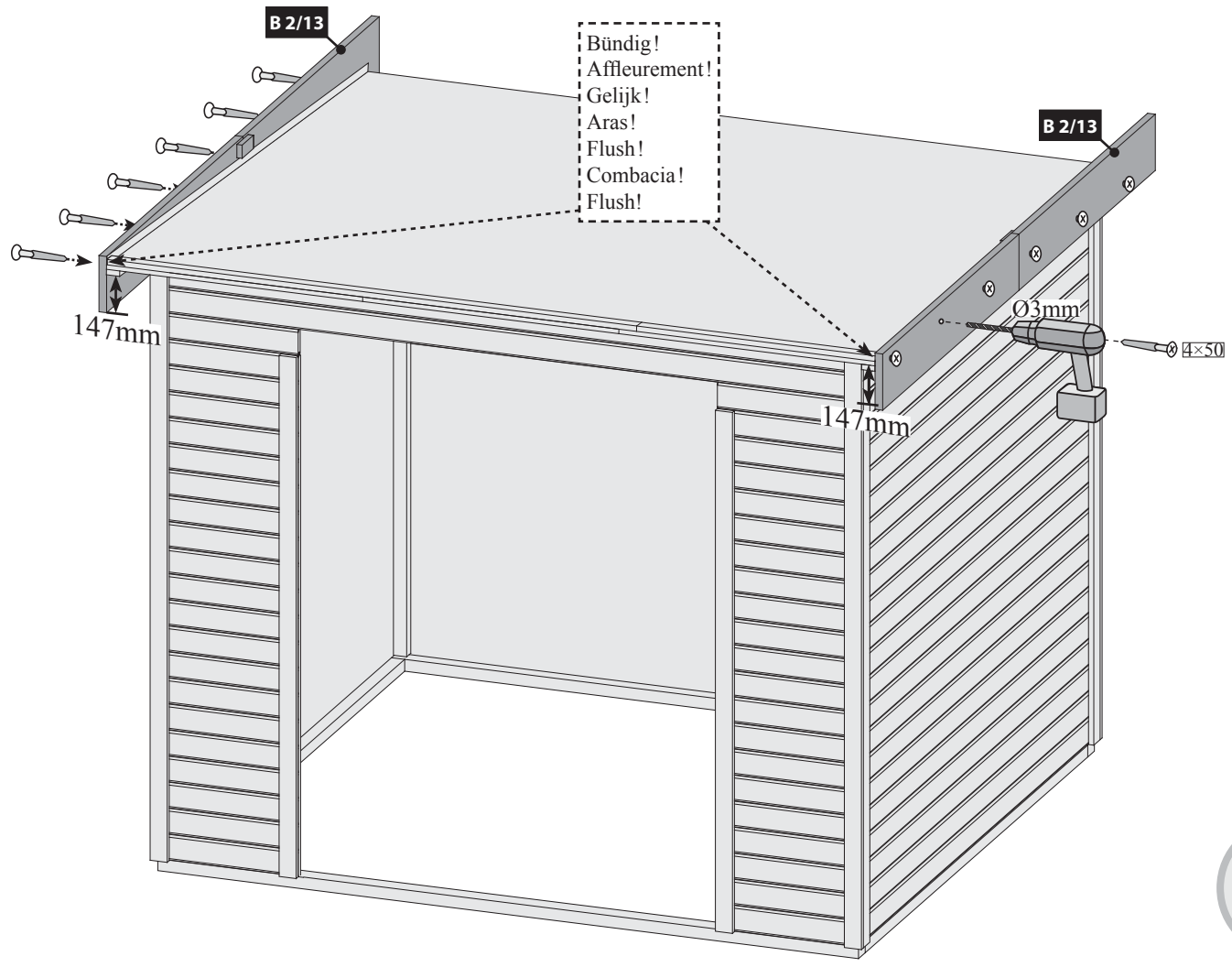

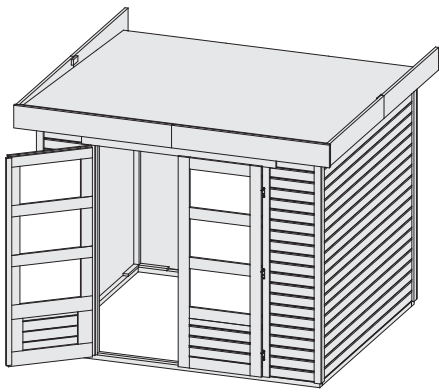

**22 A + 23 A**

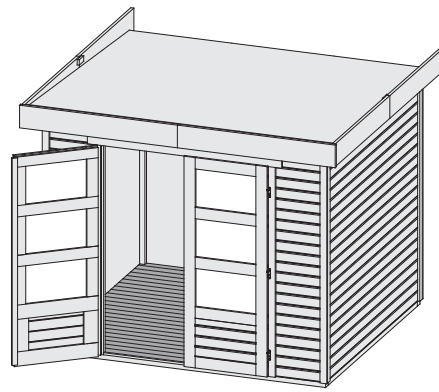

**22 B + 23 B**

**22 A**

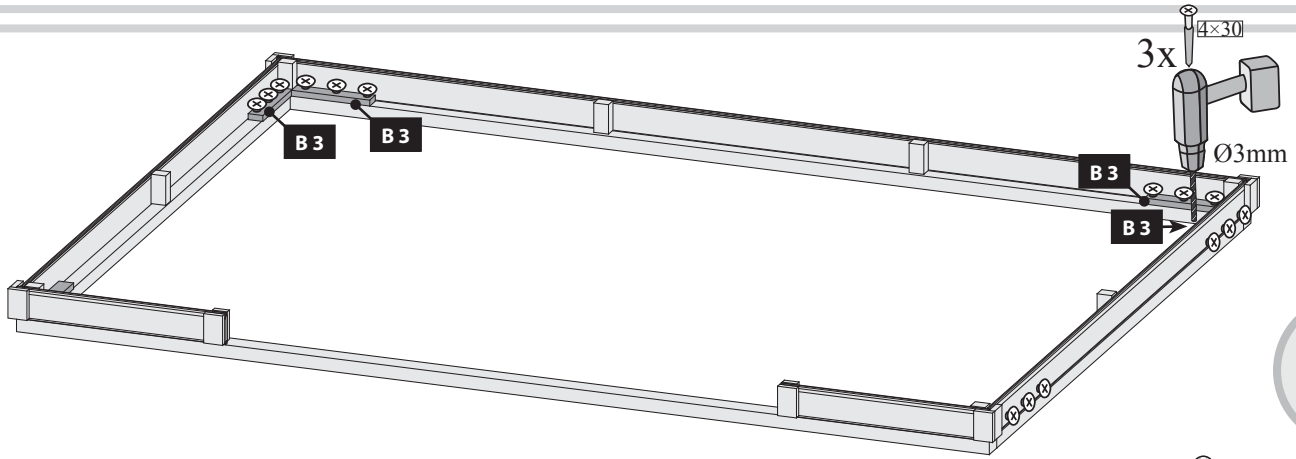

**23 A**

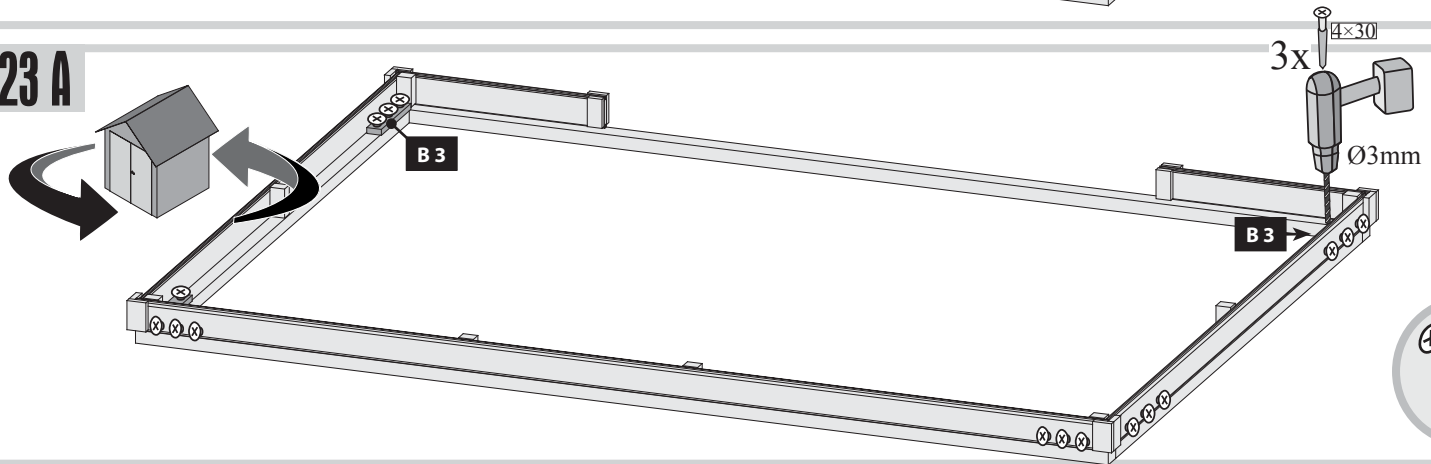

**22 B**

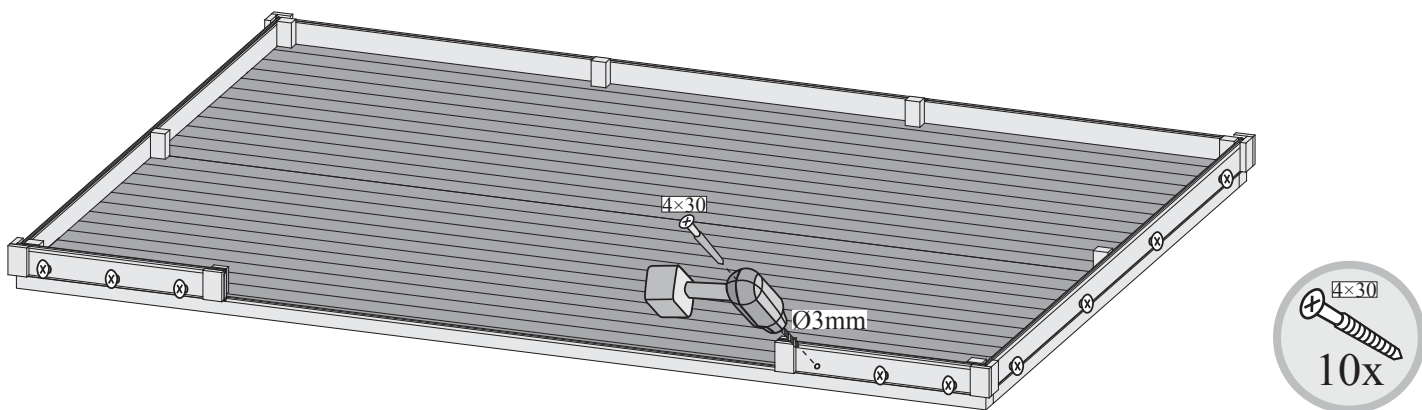

**23 B**

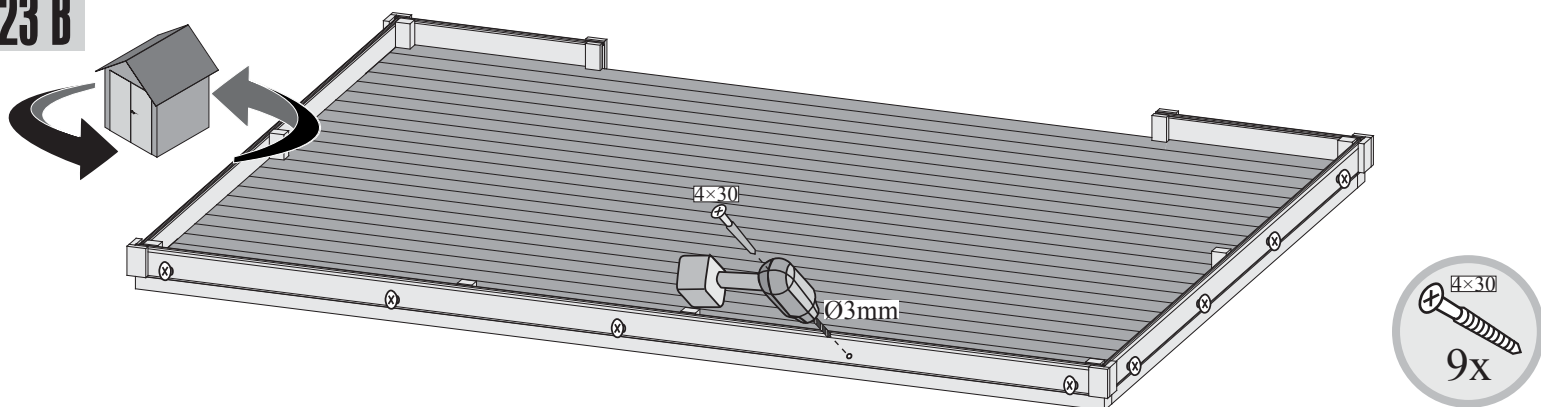

24

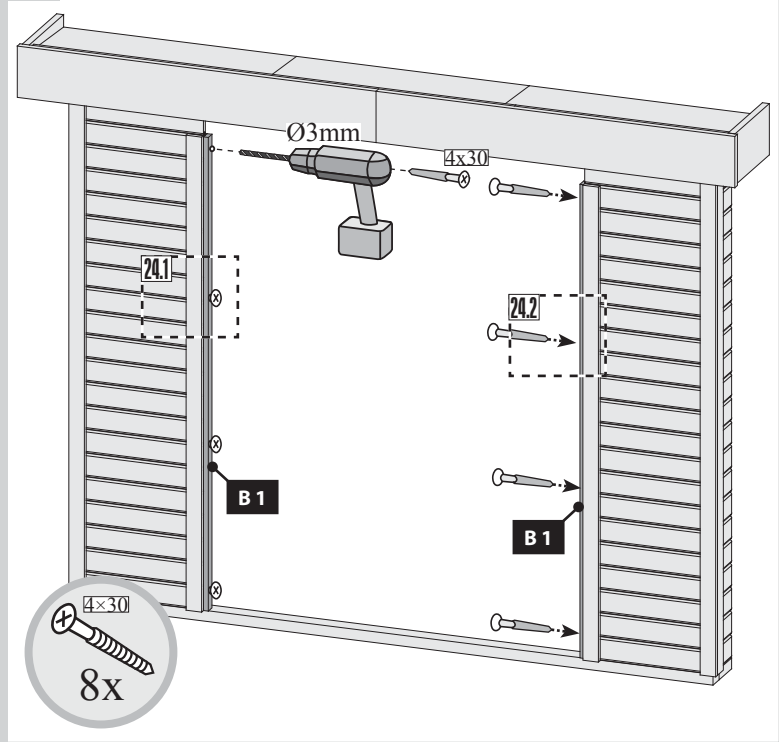

25

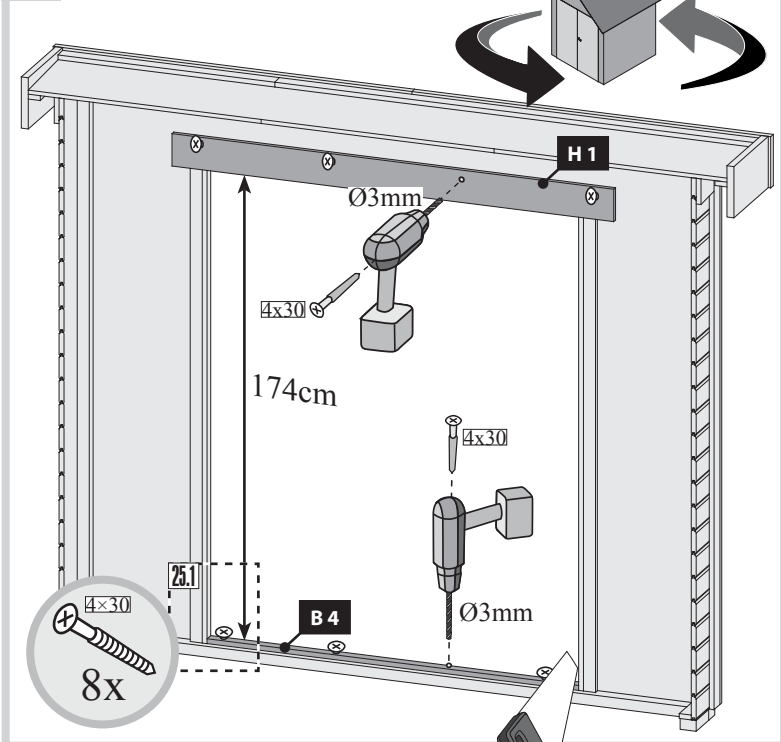

24.1

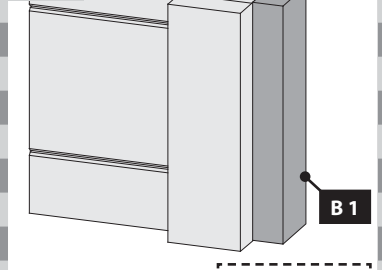

24.2

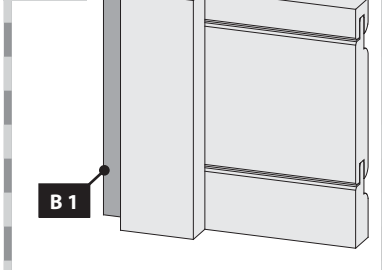

25.1

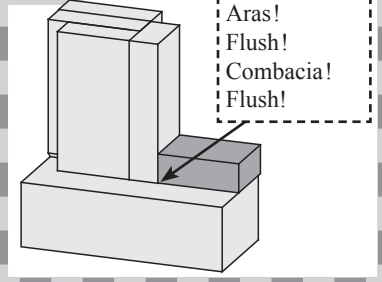

Bündig!  
Affleurement!  
Gelijk!  
Aras!  
Flush!  
Combacia!  
Flush!

26.1

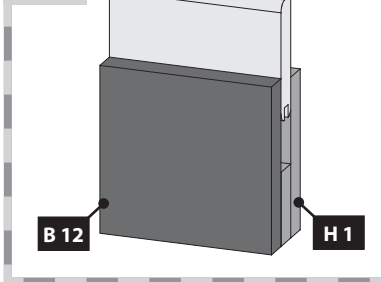

26

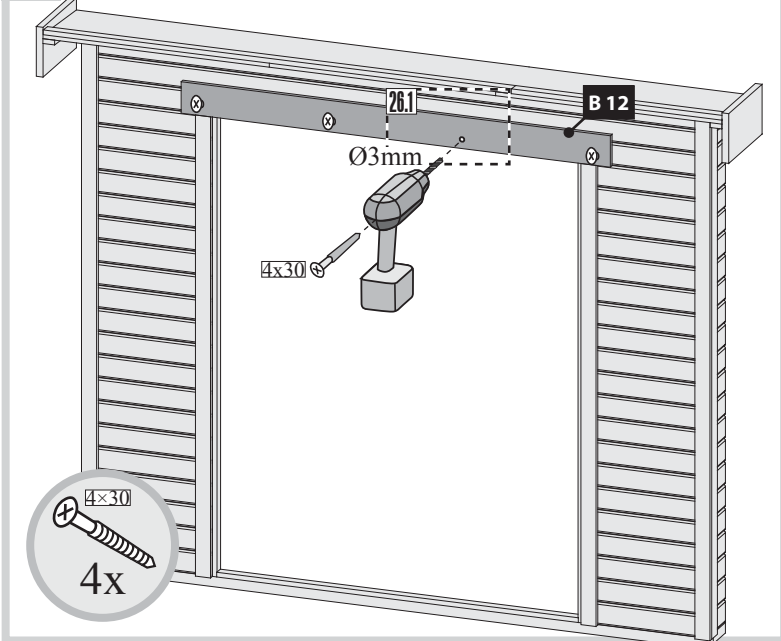

27

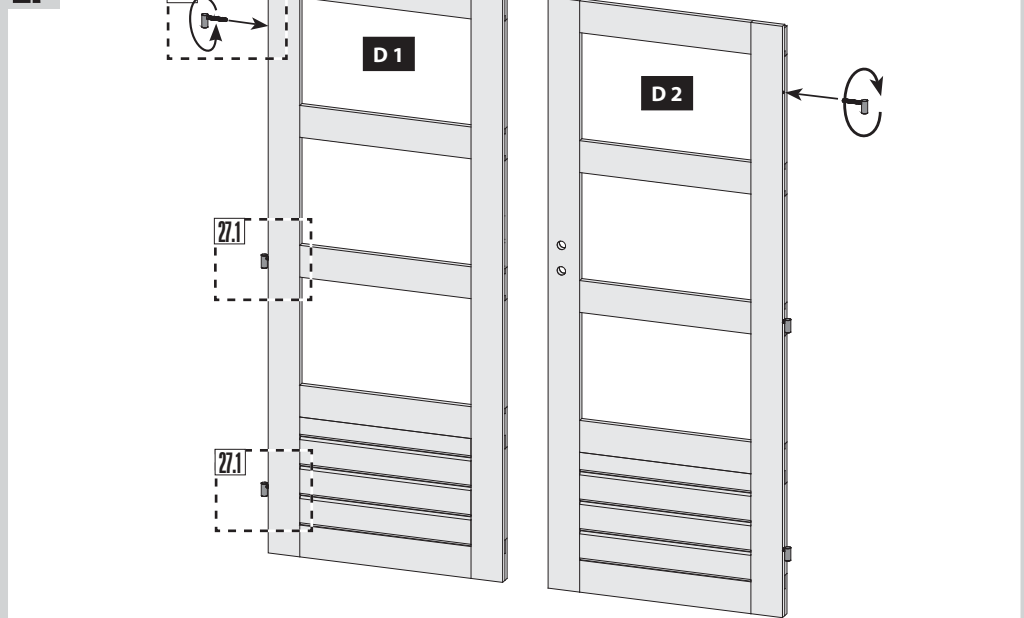

27.1-1

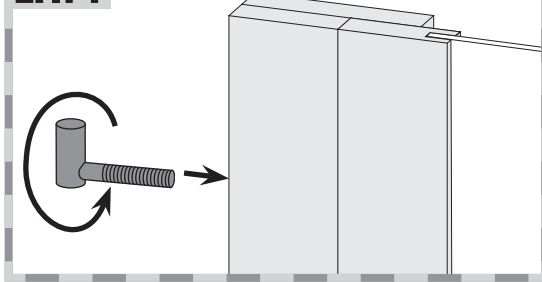

27.1-2

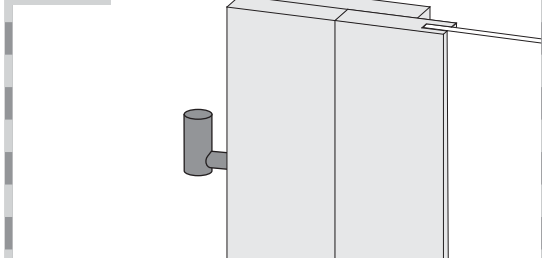

28

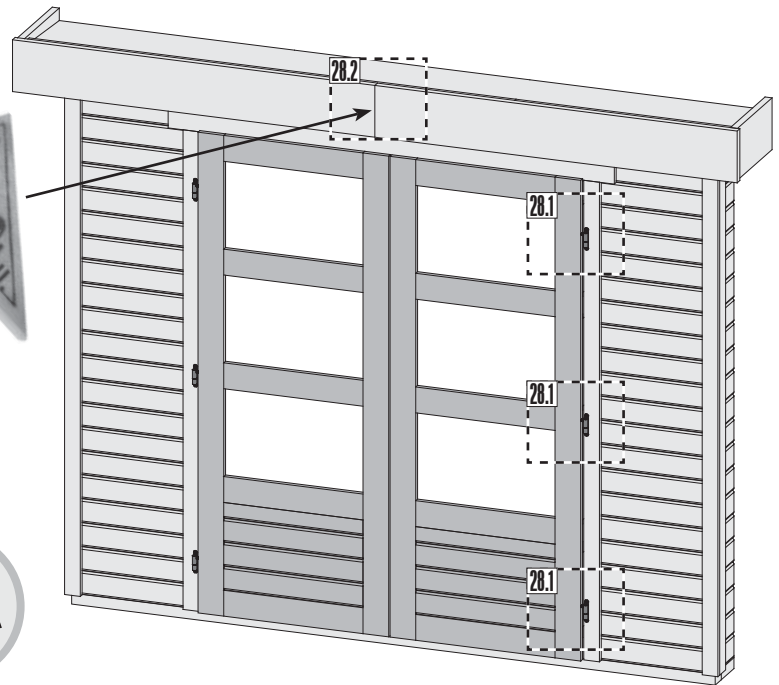

28.1-1

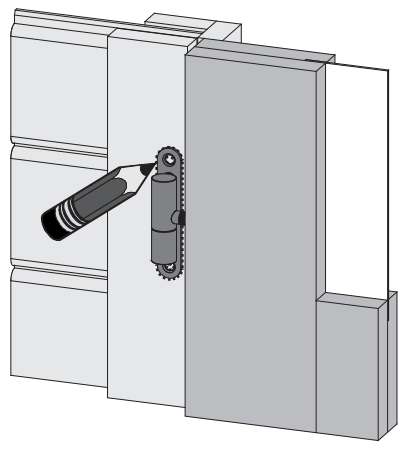

28.1-2

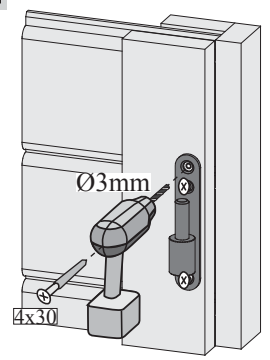

29

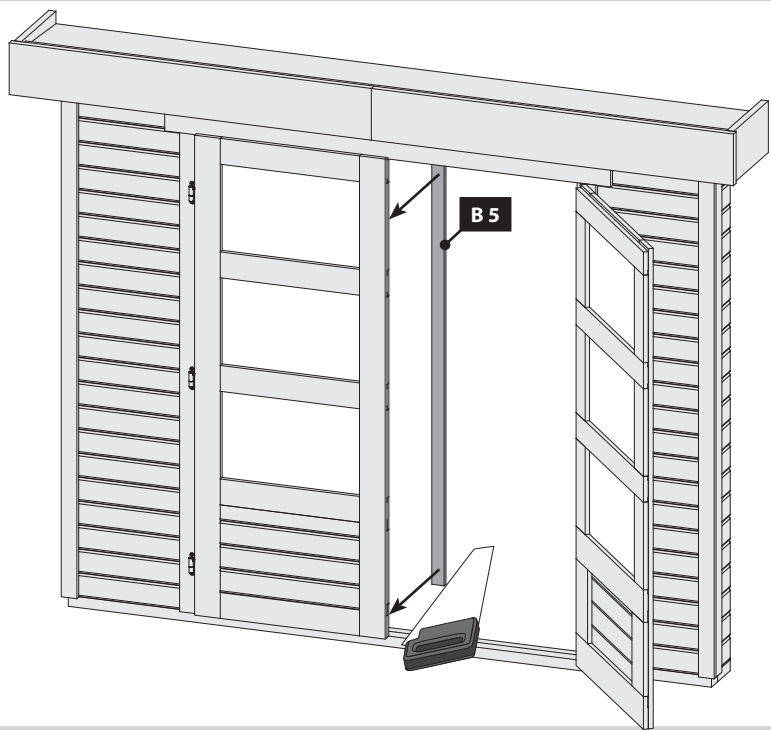

28.2

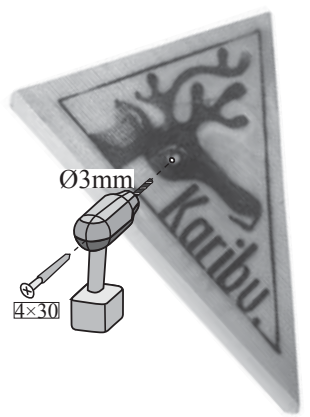

30

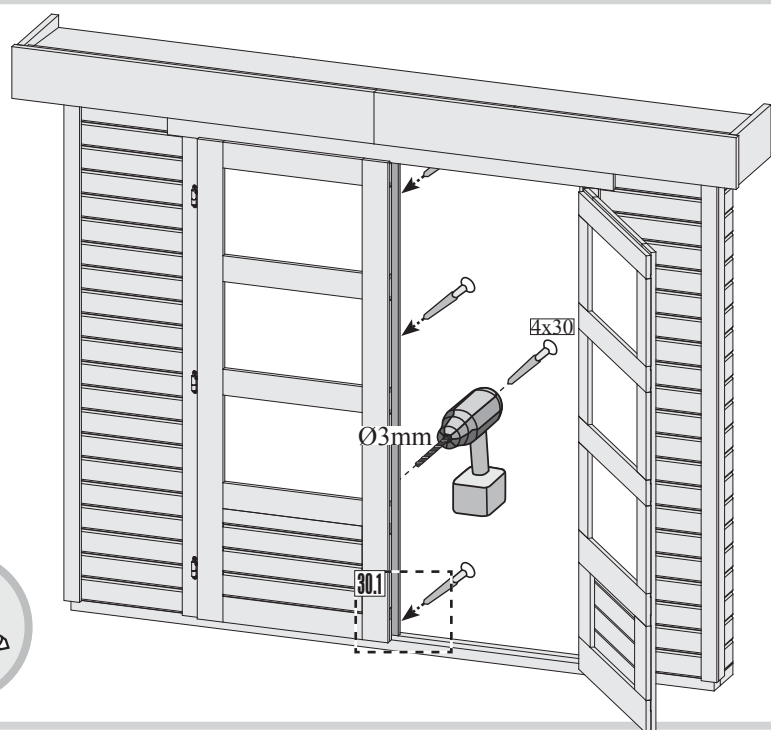

30.1

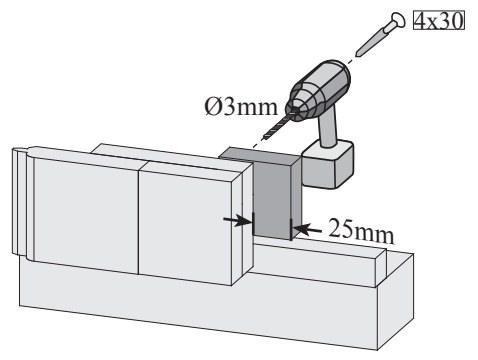

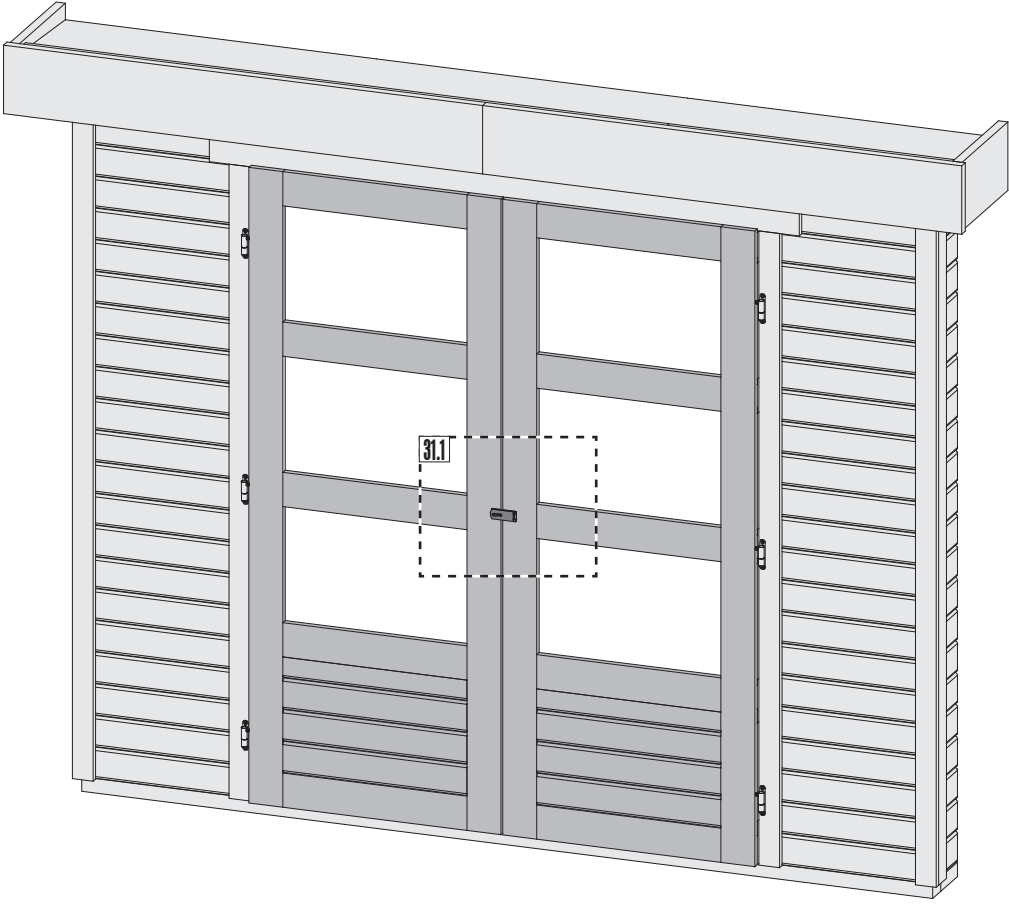

31.1-1

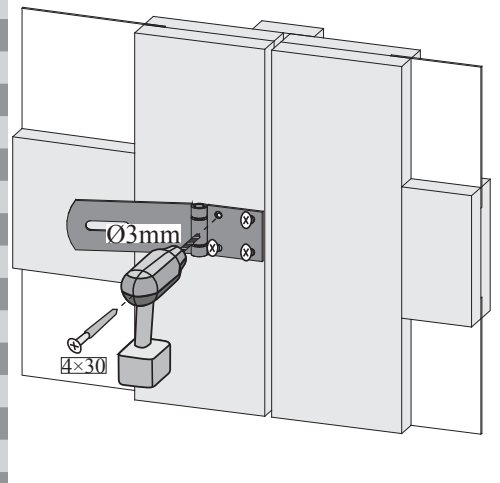

31.1-2

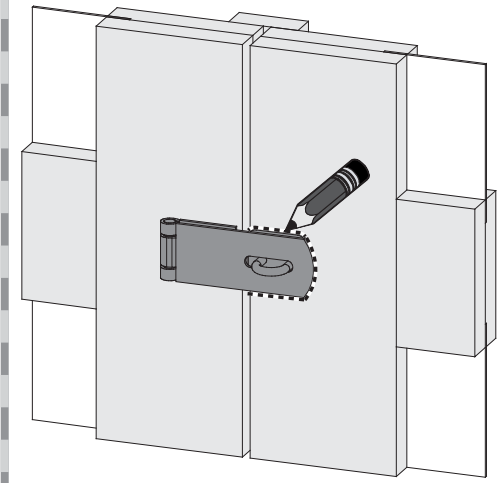

31.1-3

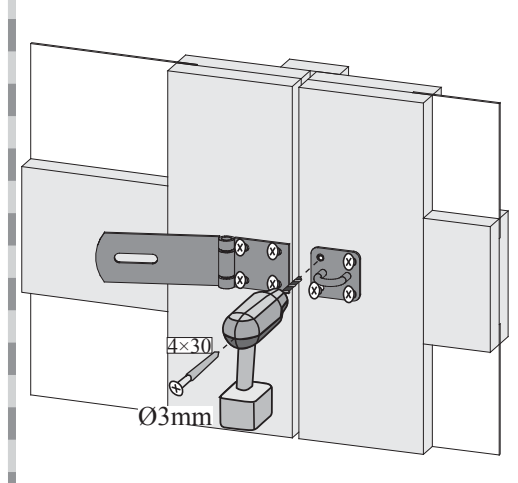

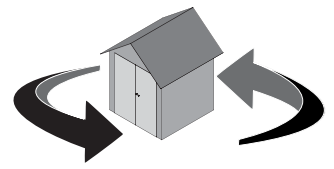
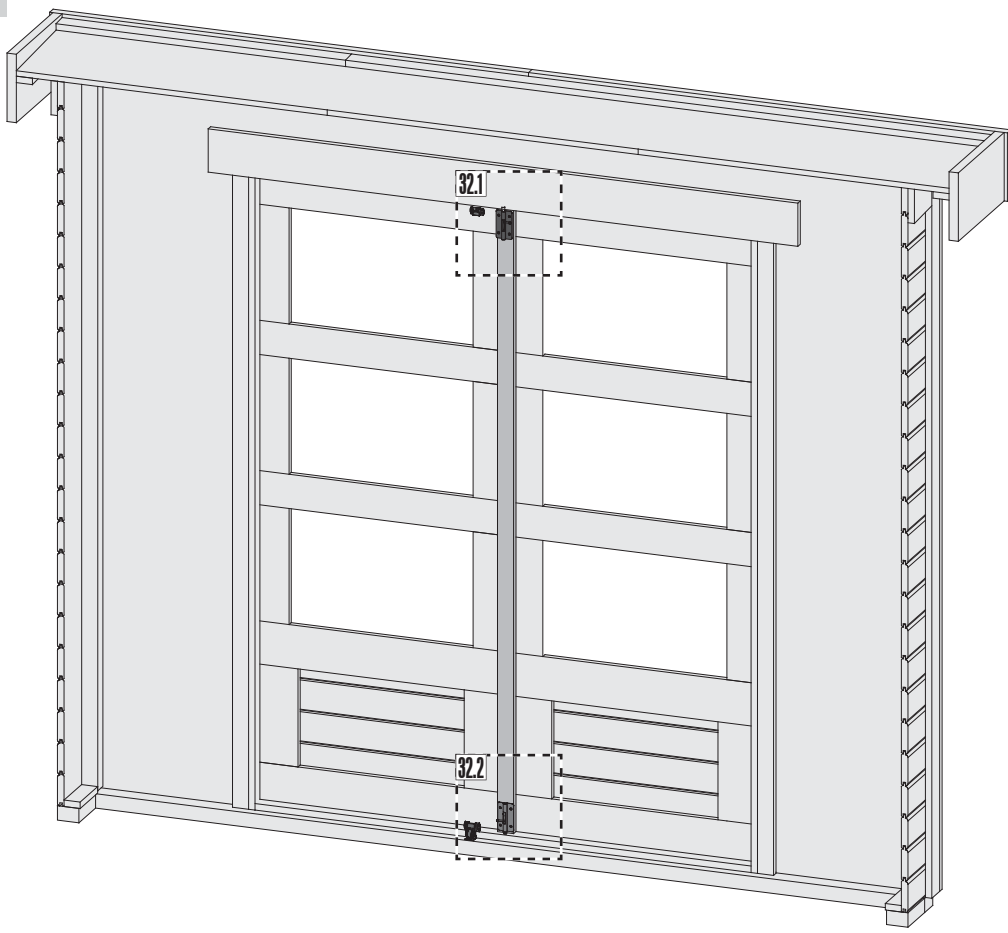

32.1-1

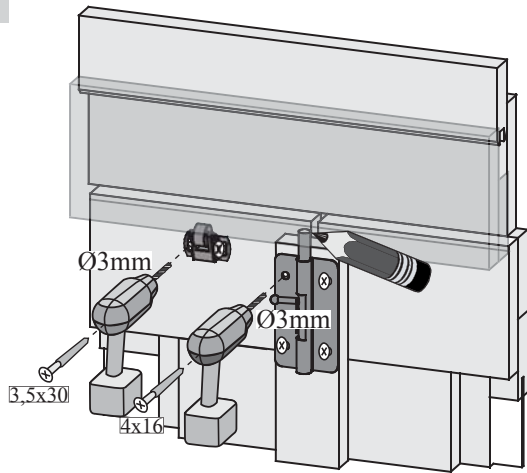

32.1-2

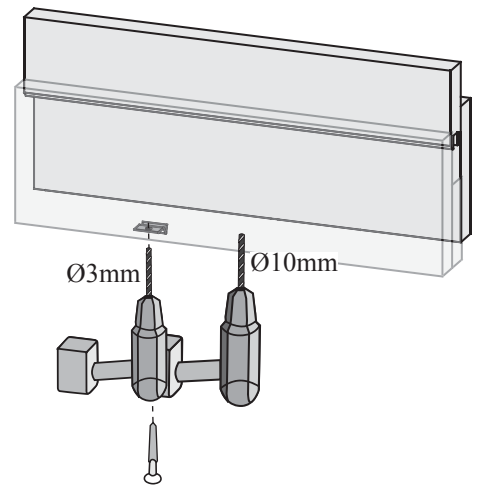

32.2-1

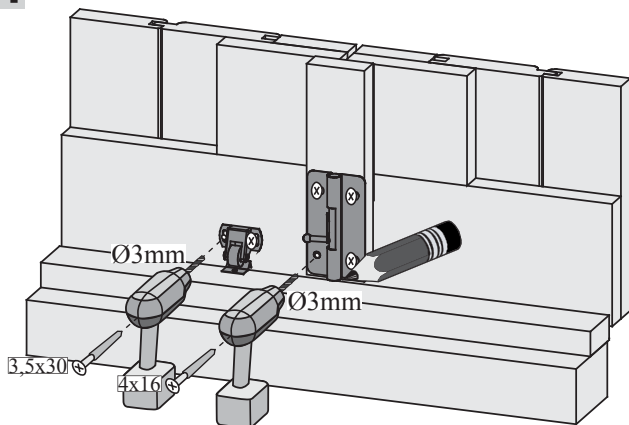

32.2-1

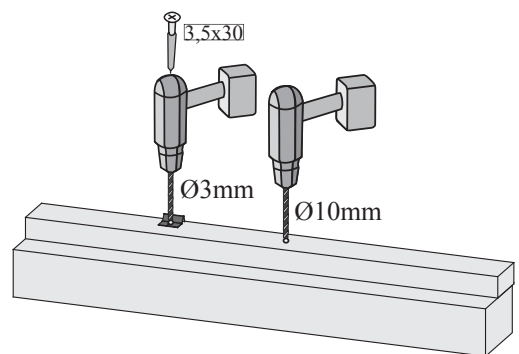

**Una corretta manutenzione è la premessa per il ricorso alla garanzia.**

Per garantire l'idoneità all'uso del portoncino e mantenerne inalterato il valore nel tempo, anche durante il periodo della garanzia sono necessarie una manutenzione e una cura adeguate che non sono comprese nell'obbligo della garanzia. Eventuali difetti devono essere corretti subito dopo il rilevamento.

**Trattamento protettivo del portoncino**

Tutte le parti in legno del portoncino devono essere sempre sottoposte a trattamento protettivo. Prima dell'installazione, è necessario eseguire il trattamento integrale dei punti che successivamente non risulteranno più accessibili. Nel caso venga utilizzato un prodotto contro il turchino, prevedere successivamente l'applicazione di un doppio strato di impregnante per legno a poro aperto. Si consiglia di ripetere l'applicazione dello strato protettivo al massimo ogni due anni. È necessario ricordare che, in caso di utilizzo di vernici non adatte, le placche in plastica inserite potranno presentare delle differenze cromatiche rispetto ai portoncini. Nel caso di edifici colorati e impregnati a pressione, il trattamento successivo interesserà solamente i punti e le parti in legno lasciati al naturale. Una copertura del colore uniforme nell'area interna deve essere raggiunta verniciando una volta la parte interna con una vernice a base di resine acriliche in dispersione acquosa a poro aperto. Per assicurare una lunga durata del prodotto, eventuali punti danneggiati devono essere riparati in modo tempestivo, carteggiando leggermente e applicando nuovamente il colore. Il vostro rivenditore di fiducia saprà consigliarvi degli impregnanti adatti. Per garantire una lunga durata del portoncino e aumentarne la tenuta all'acqua, è inoltre possibile sigillare la giunzione vetrolegno con un'apposita pasta.

**Un'esecuzione non corretta delle operazioni indicate può determinare la comparsa di deformazioni, azzurrimento e funghi sul legno di porte e telai e il conseguente decadimento della garanzia.**

**Pulizia**

Una pulizia e una cura regolari sono essenziali ai fini della durata e dell'efficienza di prodotti pregiati. La pulizia deve essere effettuata sul lato interno, su quello esterno e anche nella scanalatura nel telaio. Prima di iniziare la pulizia, verificare la compatibilità dei detergenti con il materiale da pulire.

**Deformazione del portoncino**

Il legno reagisce alle condizioni ambientali. Il rigonfiamento e il ritiro, cui può essere soggetto il legno a seconda delle condizioni atmosferiche, comportano variazioni dimensionali e lievi deformazioni. Affinchè il portoncino continui a chiudersi correttamente, può rendersi necessario un intervento sulle cerniere, avvitandole o svitandole, a seconda delle condizioni atmosferiche. Finché il funzionamento viene garantito dalle possibilità di regolazione indicate, la deformazione del portoncino è considerata accettabile. La garanzia non copre danni derivanti dall'uso di forza.

**Regolazione del portoncino**

Per assicurare il corretto funzionamento del portoncino, lo stesso deve essere posizionato con precisione. Il telaio deve essere incassato in posizione perpendicolare al pavimento e ad angolo retto. Il telaio va inoltre montato in modo da avere la stessa larghezza sia superiormente che inferiormente. Se il portoncino non si chiude o un battente non è ben bilanciato, il problema può essere corretto intervenendo sulle cerniere a vite, avvitandole e svitandole fino a 5 giri. Nel caso di portoncini a doppio battente, il battente fisso deve essere sempre assicurato verso l'alto e verso il basso per mezzo degli appositi meccanismi.

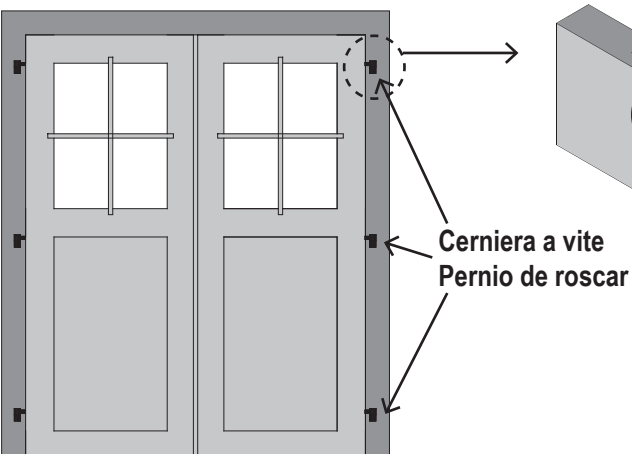

**¡Para cualquier garantía es condición previa que se realice la conservación!**

Para asegurar de forma duradera la utilidad y el valor también es necesario que se realice durante el periodo de validez de la garantía el mantenimiento y cuidado apropiados, que no están incluidos en las obligaciones de la garantía. Los defectos deberán ser reparados inmediatamente después de detectarse.

**Tratamiento técnico protector de madera de la puerta**

Todas las piezas constructivas de la puerta deberán tratarse siempre según la técnica para protección de madera. Aquellas partes o zonas de la madera que, tras el montaje, ya no serán accesibles deberán ser tratadas completamente antes de proceder a su montaje. Trate usted el producto con una imprimación protectora contra el hongo de azuleo, a continuación aplíquelo dos manos de barniz protector de madera de poros abiertos. Como muy tarde cada dos años se debería aplicar de nuevo una mano de protección. En las puertas deberá tenerse en cuenta que las planchas utilizadas pueden presentar variaciones de color, si no se utilizan los materiales de pintura apropiados. En casas de colores e impregnadas por medio de caldera a presión solamente se deberán tratar posteriormente las zonas (cortes serrados) y piezas o partes de madera que se hayan dejado al natural. En el interior se deberá conseguir una cubrición de pintura homogénea mediante la aplicación de una sola mano. A fin de garantizar una larga duración de vida útil de su producto las zonas o partes dañadas se deberán reparar de inmediato. Para ello se lijará un poco las zonas dañadas y se volverá a aplicar pintura. Infórmese sobre los barnices apropiados en su asesor técnico de colores. Para garantizar una larga duración de vida útil de la puerta y para aumentar la impermeabilidad a la lluvia que viene de lado por el viento se deberán sellar las transiciones entre la madera y el vidrio de la ventana con alguna masilla selladora adecuada. **Si no se han llevado a cabo correctamente estas medidas de conservación y cuidado, podrán producirse deformaciones, hongos de azuleo y hongos en general en las puertas, bordes y cercos, con lo que se puede extinguir la garantía.**

**Limpieza**

La limpieza y el cuidado periódicos son condición previa básica para mantener la vida útil y la funcionalidad de los productos de alta calidad. También se deberán limpiar las partes interiores y exteriores en la zona de los encajes y las ensambladuras. Los detergentes o agentes limpiadores deberán ser apropiados para cada material en cuestión. Se deberá comprobar la idoneidad de dichos agentes antes de comenzar el trabajo.

**Deformación de la puerta**

La madera reacciona a las influencias del medio ambiente. Así, según el clima que haga, pueden producirse hinchamientos y encogimientos de la madera. Debido a este fenómeno se producen variaciones o desviaciones de las medidas y dimensiones y, por tanto, ligeras deformaciones. Para mantener la capacidad de cierre de la puerta se adaptará la misma, según las condiciones climáticas y sus repercusiones, girando hacia fuera o hacia adentro los pernios. Se podrá aceptar una deformación de la puerta, siempre que su funcionamiento siga garantizado mediante las posibilidades de ajuste indicadas en las presentes instrucciones. No se asumirá garantía alguna por aquellos daños que hayan sido causados por acción violenta.

**Ajustar la puerta**

La puerta deberá estar exactamente alineada a fin de que su funcionamiento perfecto esté garantizado. El marco de la puerta deberá estar montado en ángulo recto y perpendicularmente. Asimismo el marco de la puerta deberá estar montado de manera que tenga el mismo ancho arriba que abajo. Si la puerta no cierra o una hoja de la misma está torcida, se podrá corregir roscando o desenroscando un poco los pernios. Estos pernios se pueden desenroscar hasta 5 vueltas. Si tiene usted una puerta de dos hojas, la hoja de retención siempre se deberá fijar tanto arriba como abajo con los herrajes correspondientes previstos para dicho fin.

**Esempio di regolazione del portoncino:  
Ejemplos para ajustar las puerta:**

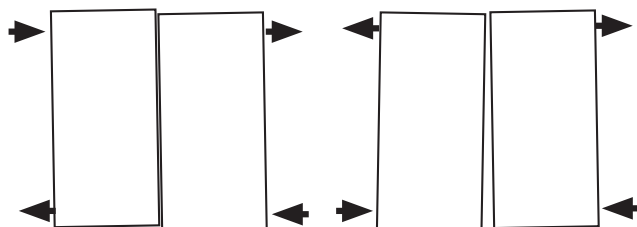



## Ošetřování a údržba dveří

### Údržba je předpokladem pro zachování záruky!

Pro udržení trvalé funkčnosti a dobrého stavu je třeba i během záruční lhůty provádět odbornou péči a údržbu, která není zahrnuta v záručních podmínkách. Veškerá poškození musí být ihned po jejich zjištění odstraněna.

### Ochranný nátěr dřevěných dveří:

Všechny části dveří musí být ošetřeny ochranným nátěrem. Místa, která budou po montáži nedostupná, je třeba ošetřit ještě před montáží. Nejprve ošetřete výrobek nátěrem pro ochranu dřeva proti zamodralosti, následně jej opatřete dvojí vrstvou ochranné lazury s otevřenými póry. Nejpozději každé dva roky byste měli ochranný nátěr nanést znovu. U dveří je třeba dát pozor na to, aby při použití nevhodných nátěrových látek nedošlo k barevným odlišnostem mezi použitými deskami a dveřmi. U barvených a tlakovou impregnací ošetřených domků je třeba ošetřit pouze ty části a díly, které nebyly dosud ošetřeny (např. Vámi provedené řezy). Souvislý barevný nátěr ve vnitřní části získáte jedním natřením. Použijte k tomu disperzní vodou ředitelný lak s otevřenými póry na bázi akrylové pryskyřice. Aby byla zachována dlouhá životnost produktu, měla by být poškozená místa ihned opravena. Poškozené místo byste měli nejprve lehce obrousit a poté znovu opatřit barevným nátěrem. Na použití vhodných lazur se informujte u odborníků. Pro udržení dlouhé životnosti dveří a zvýšení jejich odolnosti proti prudkému dešti je možno utěsnit přechod mezi tabulí skla a dřevem příslušnou těsnící hmotou.

**Pokud nebudou tato opatření řádně provedena, může dojít u dveří a zárubní k deformacím, zamodráním, nebo napadení houbou a tím i ztrátě záruky.**

### Čištění

Pravidelné čištění a péče jsou základním předpokladem pro udržení dlouhé životnosti a funkčnosti produktu. Je třeba čistit vnitřní i vnější stranu, a stejně tak oblast záhybů. Je třeba používat čisticí prostředky k tomu určené, což je třeba před započatím práce znovu překontrolovat.

### Deformace dveří

Dřevo reaguje na vlivy okolního prostředí. Tím dochází k bobtnání a vysychání dřeva. Vznikají tak lehké rozměrové odchylky a deformace. Aby byla zachována těsnost dveří, je třeba dveře vyrovnat zašroubováním nebo vyšroubováním závěsů dveří. **Pokřivení dřeva je akceptovatelné do té míry, pokud je možno pomocí výše uvedených úprav zaručit jeho funkčnost.**

Na škody, které jsou způsobeny použitím síly se záruka nevztahuje.

### Nastavení dveří

Dveře musí být přesně vyrovnány, aby byla zaručena jejich bezchybná funkčnost. Rám dveří musí být pravoúhlý a kolmý. Zároveň musí být rám umístěn tak, aby měl nahoře i dole stejnou šířku. Pokud nelze dveře zavřít, nebo jsou dveře nakřivo, je možné toto upravit zašroubováním nebo vyšroubováním závěsů dveří. Závěsy lze vyšroubovat až o 5 otočení. Pokud máte dvoukřídlové dveře, musí být pevně stojící křídlo vždy nahoře a dole zajištěno aretací.

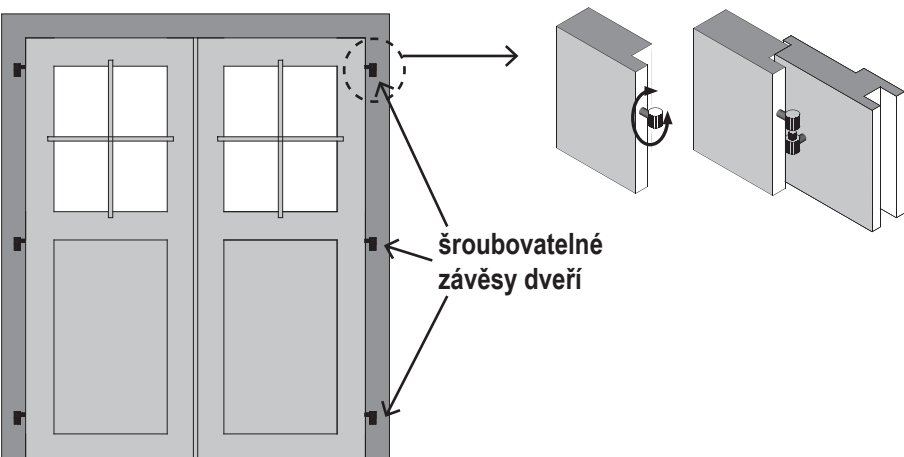

### Příklady srovnání dveří:

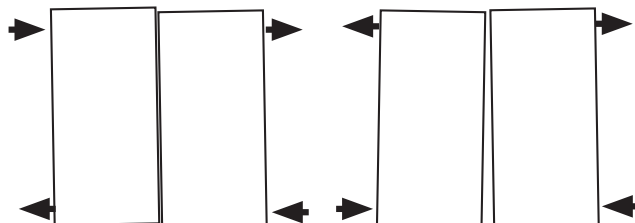

# 17026 17027

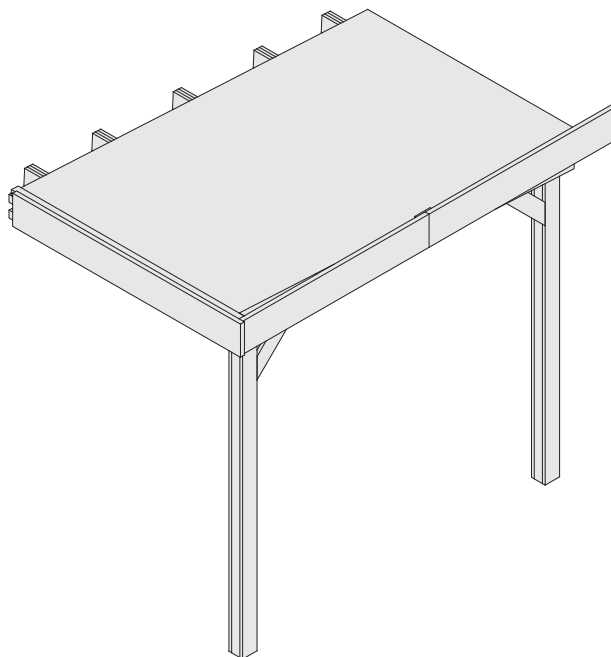

-  **Aufbauanleitung**
-  **Building Instructions**
-  **notice de montage**
-  **montagehandleiding**
-  **Montagevejledning**
-  **Instrucciones de construcción**
-  **Istruzioni per il montaggio**
-  **Montážní návod**

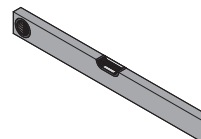
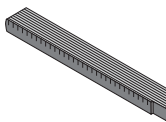
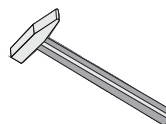
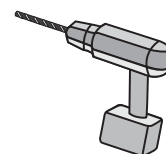
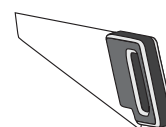



Vergleichen Sie zuerst die Material-liste mit Ihrem Paketinhalt! Bitte haben Sie Verständnis, dass Beanstandungen nur im nicht aufgebauten Zustand bearbeitet werden können!



Vergelijk eerst de lijst van materialen met de inhoud van uw pakket! Reclamaties kunnen alleen in behandeling worden genomen zolang de onderdelen nog niet zijn gemonteerd!



Confrontate questa distinta materiali prima con il contenuto del pacchetto! Vi preghiamo di comprendere che eventuali reclami possono essere accolti solo prima del montaggio!



First compare the list of materials with your package contents! Please understand that complaints can be processed in the non-built status only!



Start med at kontrollere materialelisten med indholdet af den leverede pakke! Vi gør venligst opmærksom på at reklamationer kun kan behandles for materialer som ikke er blevet bearbejdet!



Nejprve přezkontrolujte obsah balení podle materiálového listu! Mějte pochopení pro to, že případnou reklamaci se můžeme zabývat pouze tehdy, když díly nebudou smontované! Za pomoci tohoto seznamu můžete jednotlivé díly přiřadit k montážnímu návodu.



Commencez par comparer la liste du matériel avec le contenu de votre paquet! Sachez que nous traitons uniquement les réclamations concernant le matériel à l'état non monté!



En primer lugar, compare la lista de material con el contenido del paquete. Rogamos entienda que las reclamaciones sólo pueden ser tramitadas antes de montar el objeto!

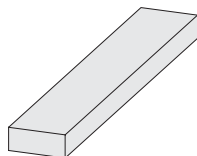
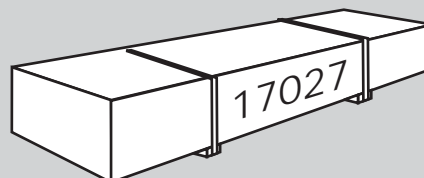
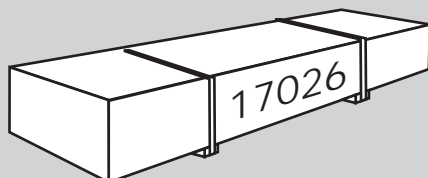

2 x B1	100 x 45 x 18 mm	ID 19114
2 x B2	1800 x 45 x 18 mm	ID 19546
4 x B3	600 x 95 x 18 mm	ID 11422
4 x B4	2200 x 95 x 18 mm	ID 52334
15 x B5	1593 x 95 x 18 mm	ID 17334
1 x B6	1500 x 190 x 26 mm	ID 16792
2 x B7	90 x 54 x 36 mm	ID 61513

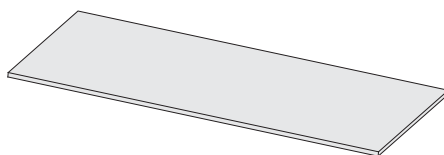

2 x N1	750 x 610 x 16 mm	ID 58036
2 x N2	1740 x 750 x 16 mm	ID 24227

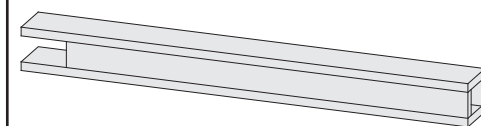

2 x G2	2025 x 95 x 90 mm	ID 61523
--------	-------------------	----------

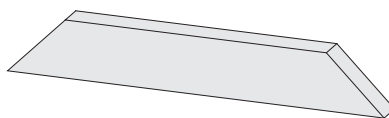

4 x G1	540 x 95 x 18 mm	ID 17869
--------	------------------	----------

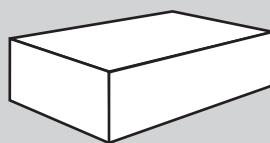

10 x



ID 21292





110 x 4 x 30mm ID 3686

115 x 4 x 50mm ID 3688

80 x 4 x 70mm ID

 Übersicht  
 Overview  
 enquête

 overzicht  
 undersøgelse  
 estudio

 sondaggio  
 přehled

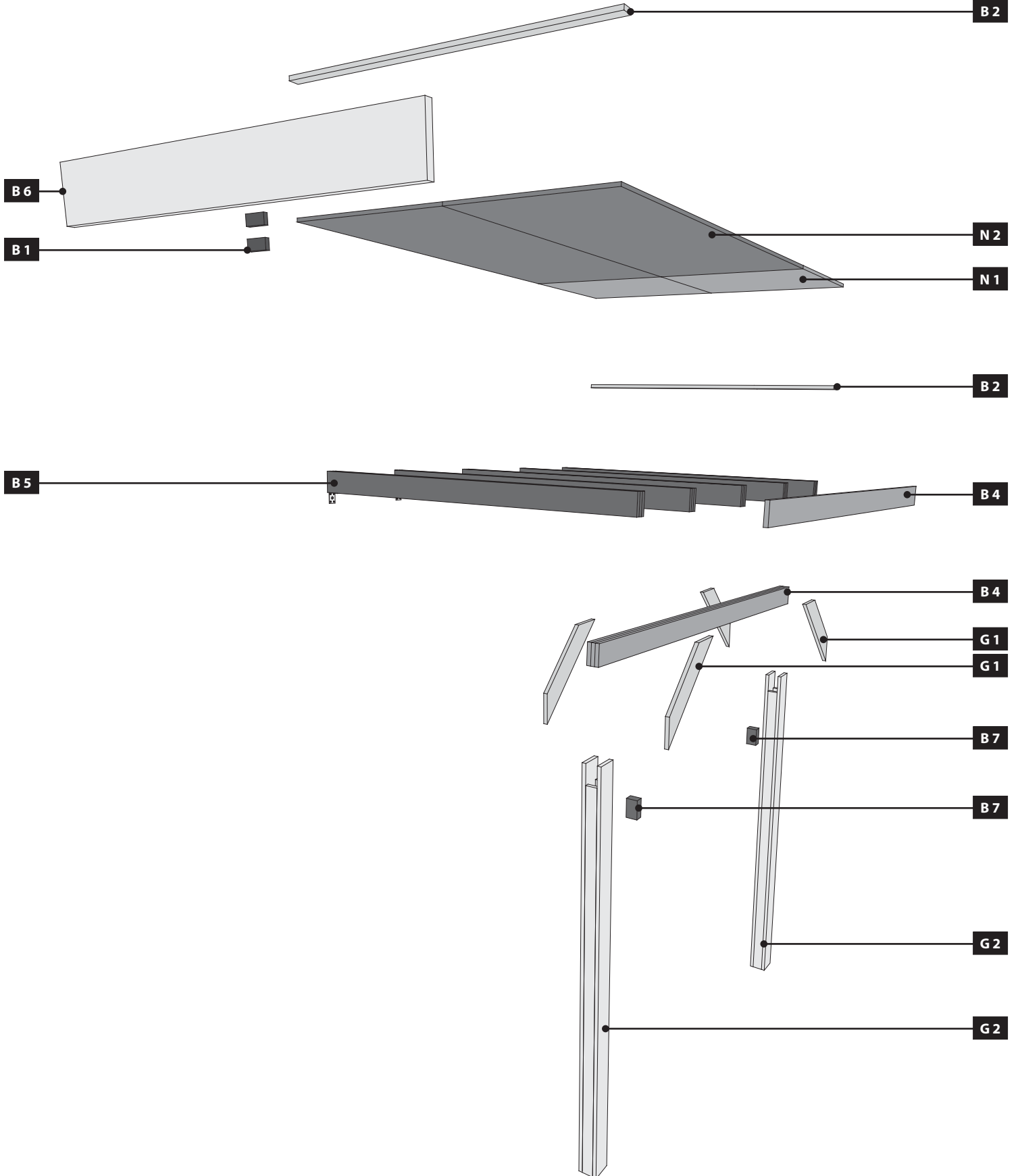



Alle anderen Häuser



Toutes les autres maisons



All other houses



Alle andere huizen



Todas las demás casas



Tutte le altre case



Všechny ostatní domy

01 2x

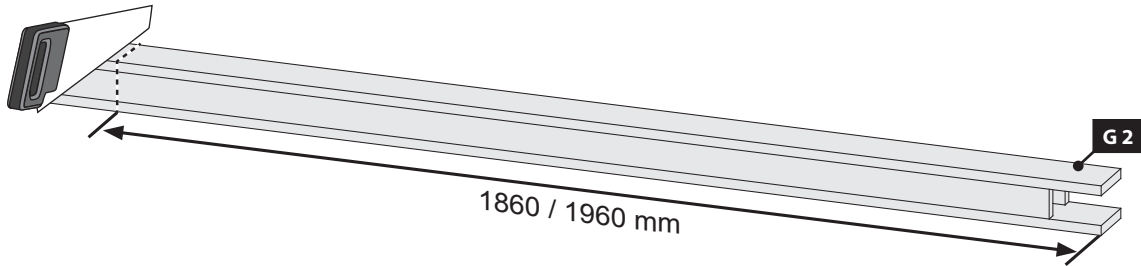

02 5x

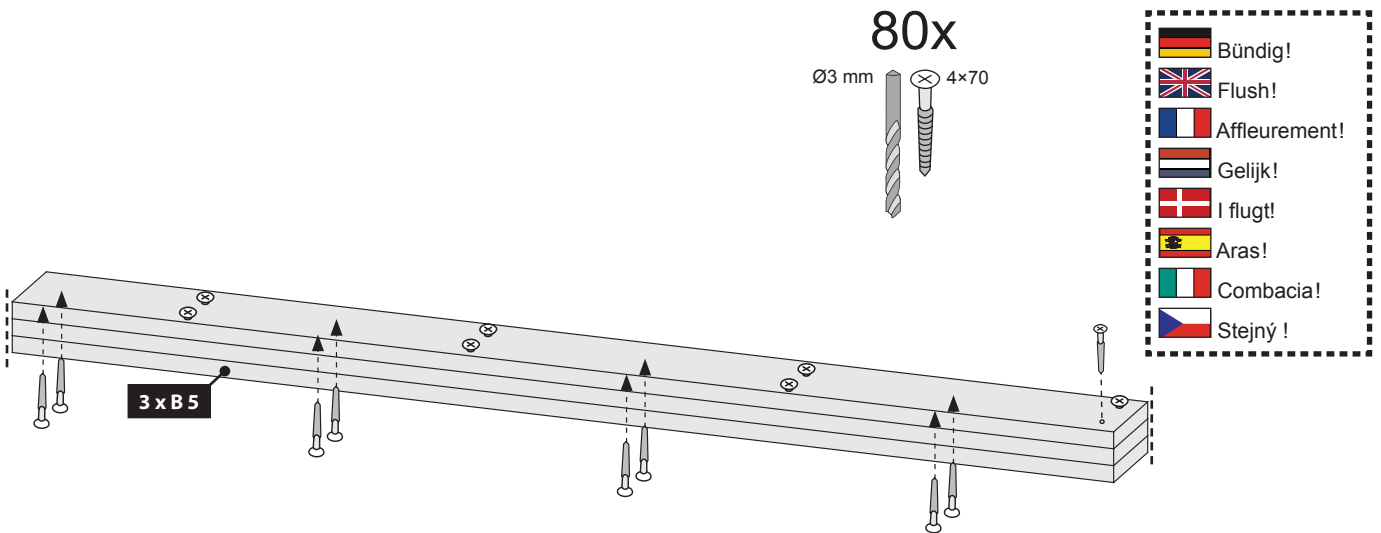

03

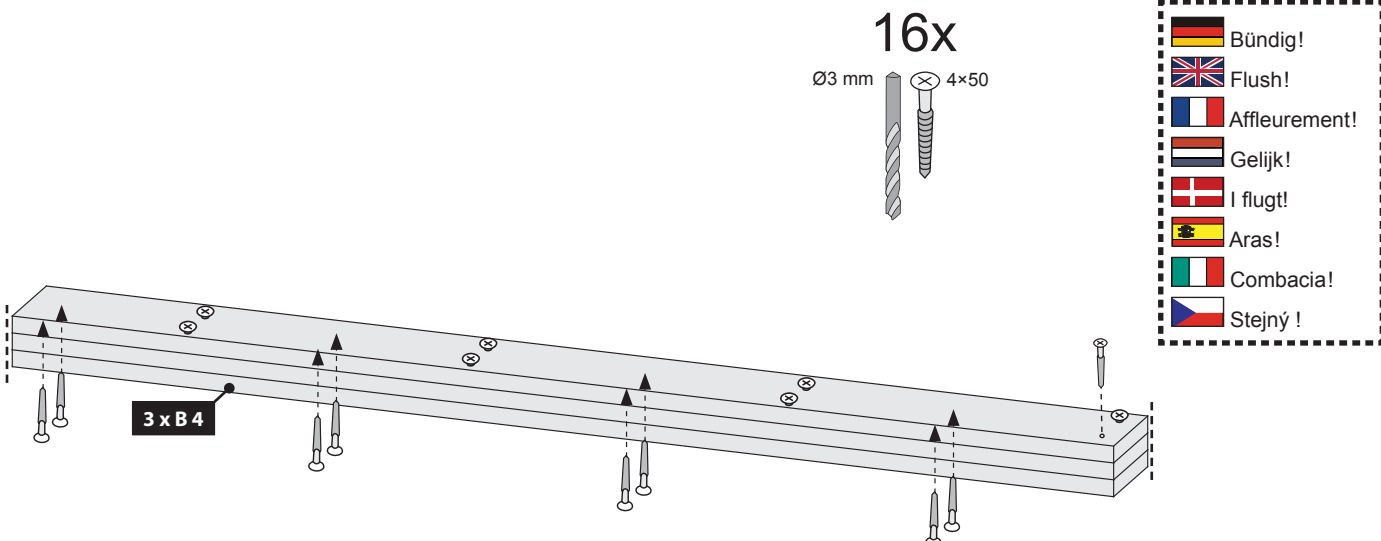

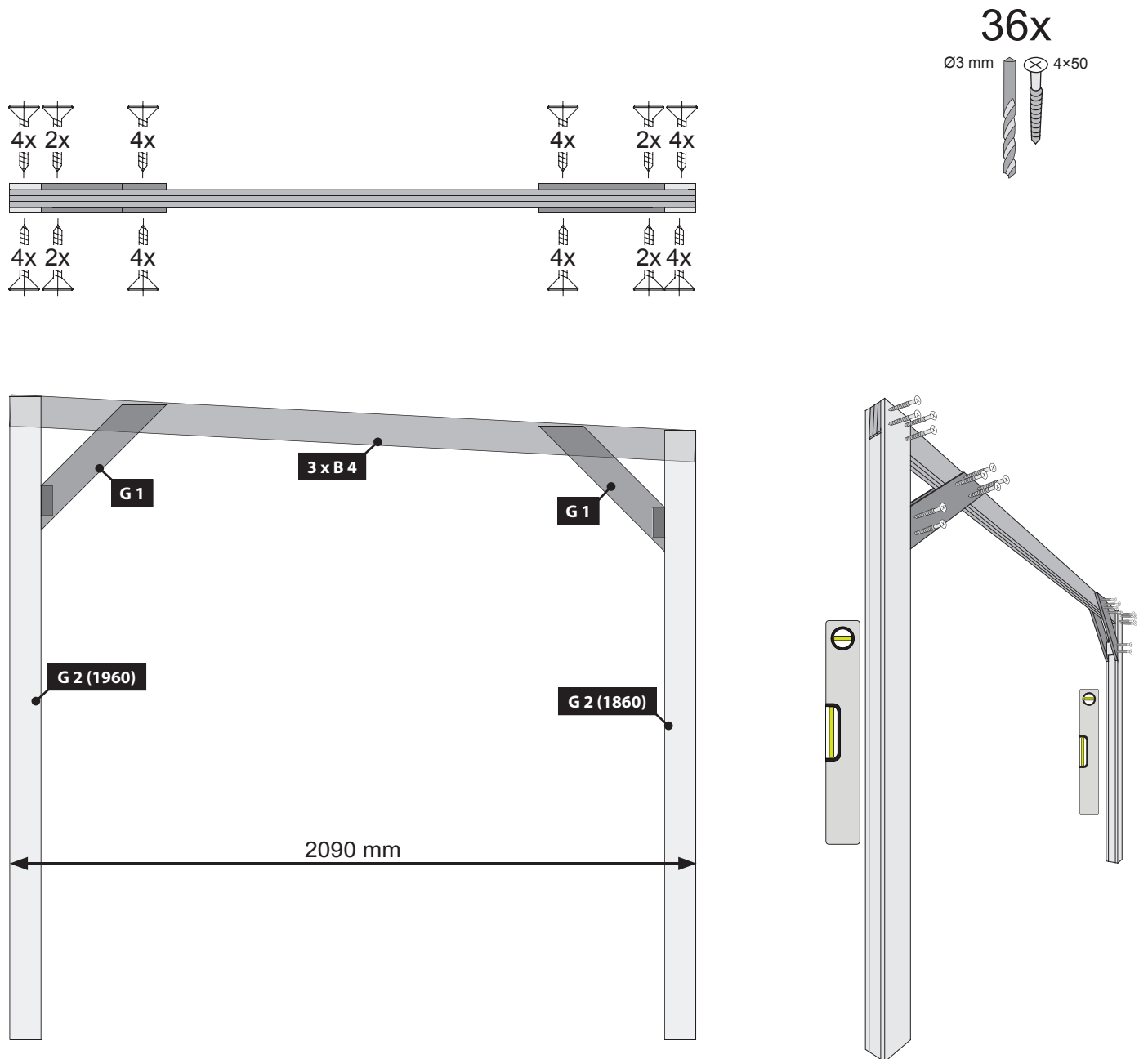
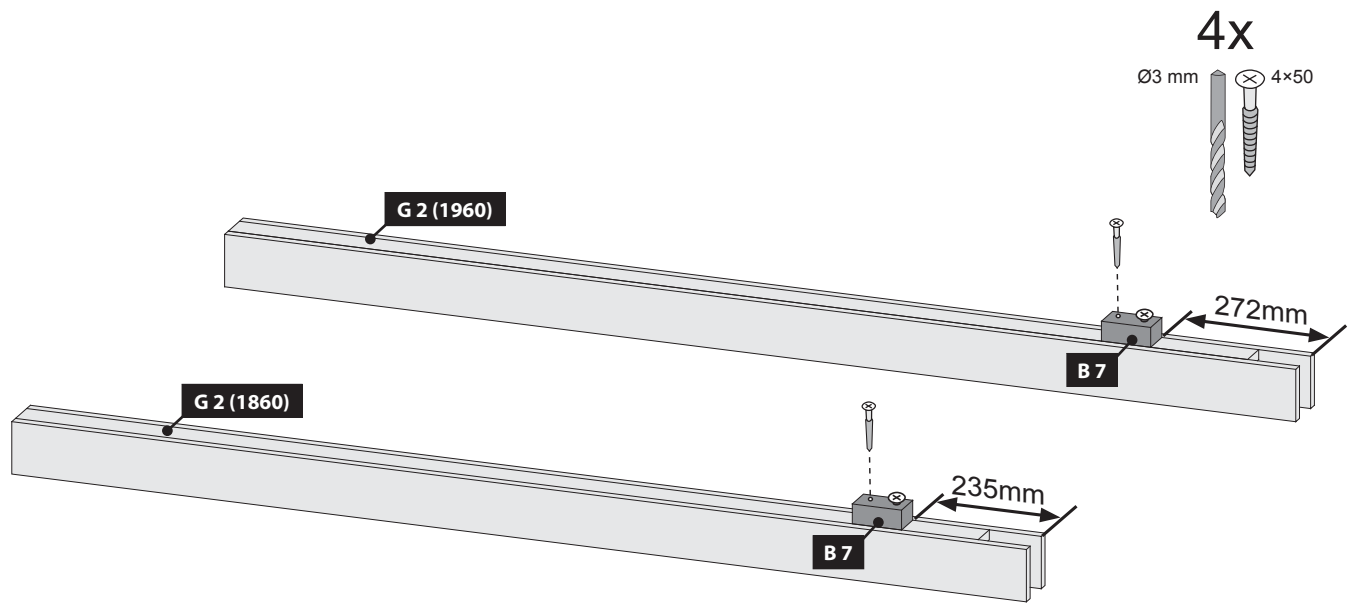

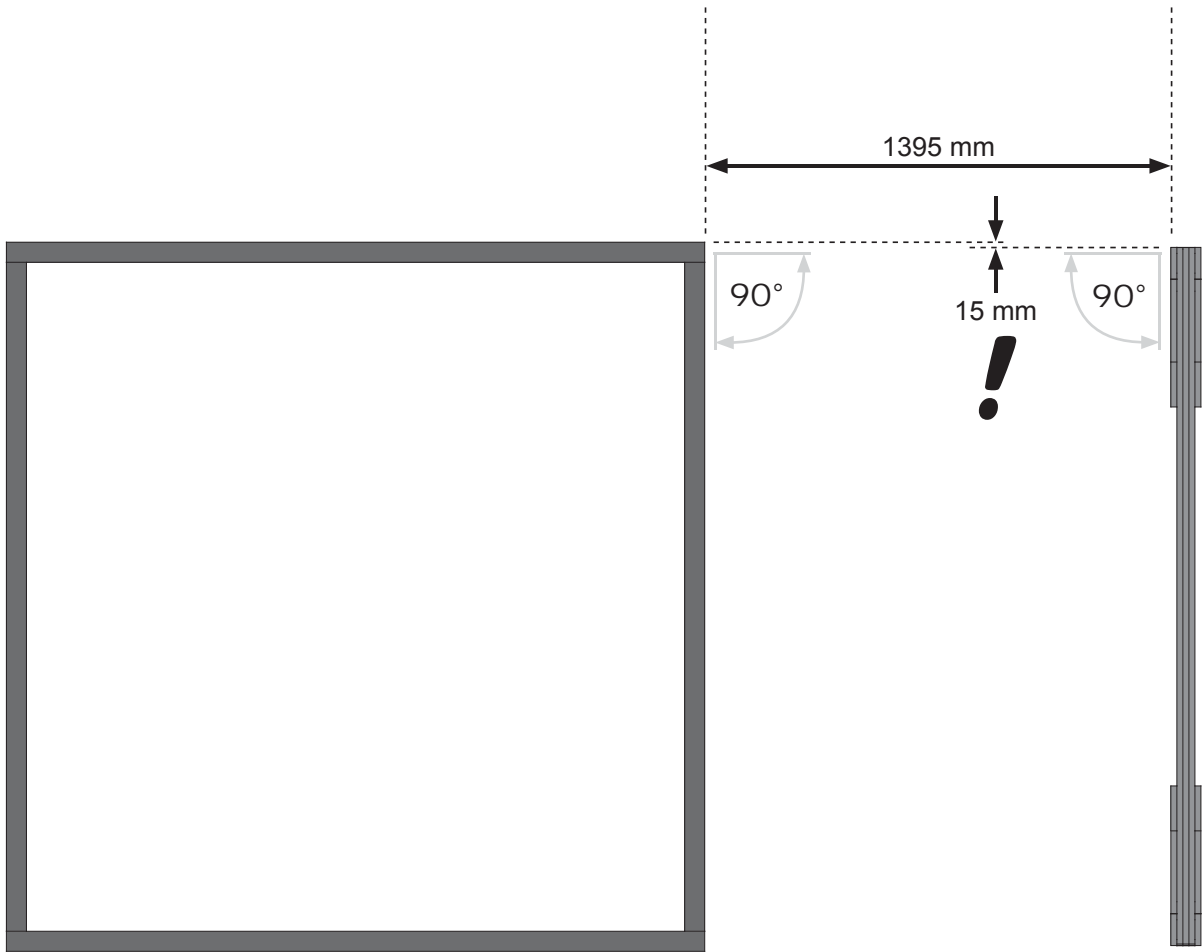
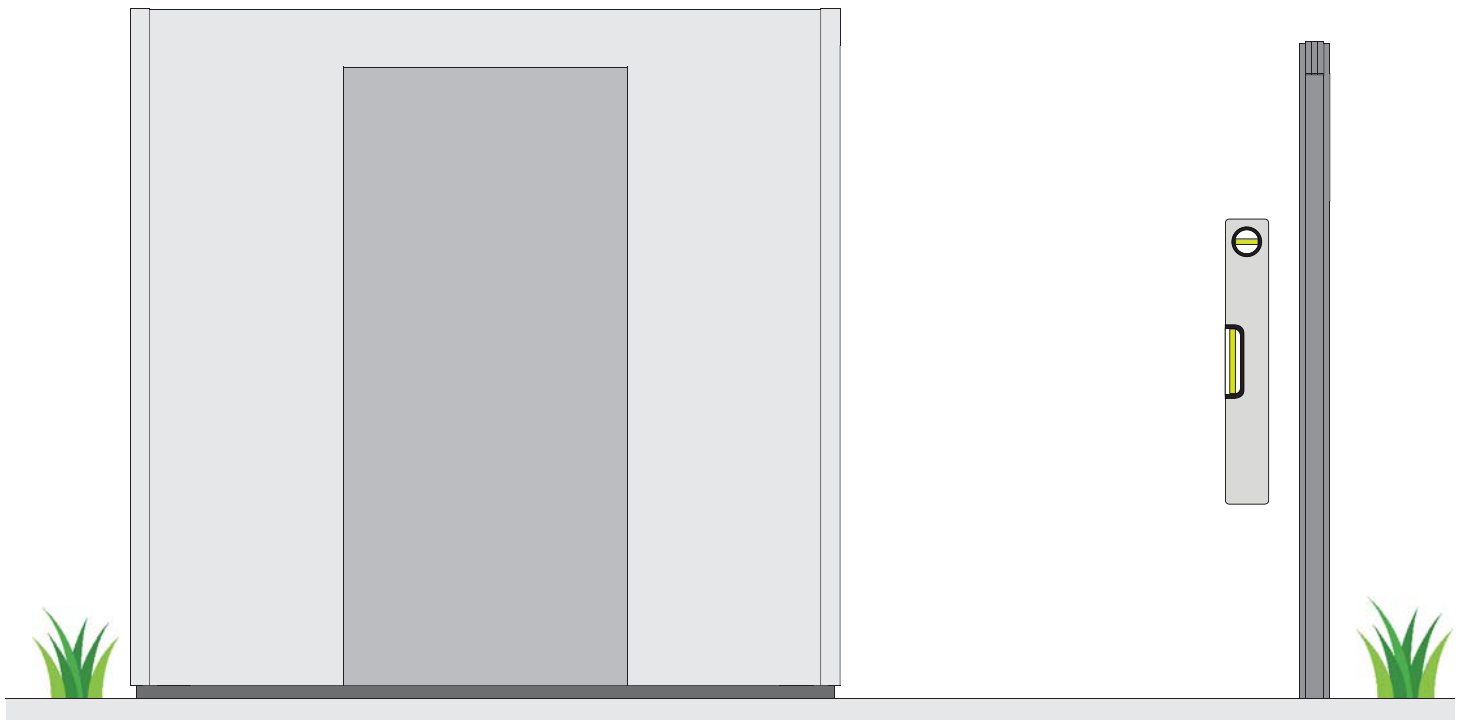

-  Bündig!
-  Flush!
-  Affleurement!
-  Gelijk!
-  I flugt!
-  Aras!
-  Combacia!
-  Stejný !

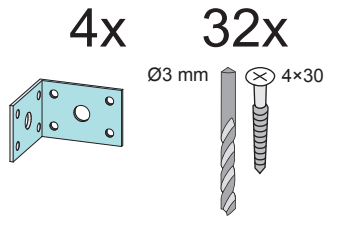
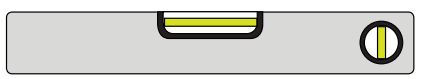
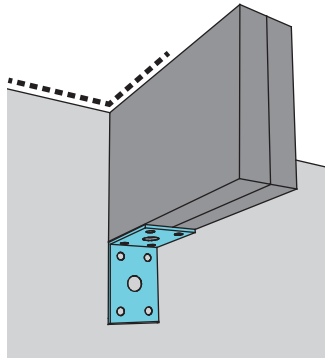

-  Draufsicht
-  Top view
-  vue de dessus
-  bovenaanzicht
-  vista desde arriba
-  vista desde arriba
-  vista dall'alto
-  pùdorys

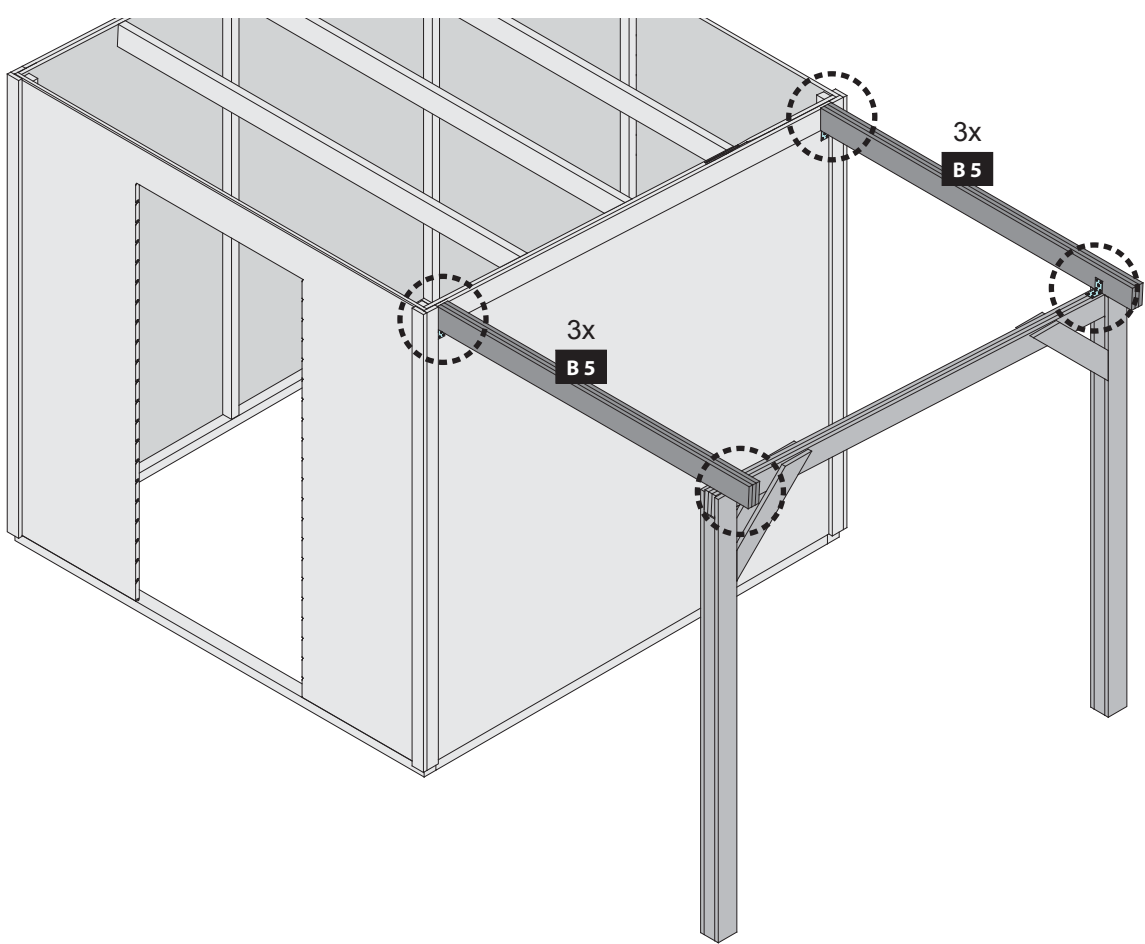
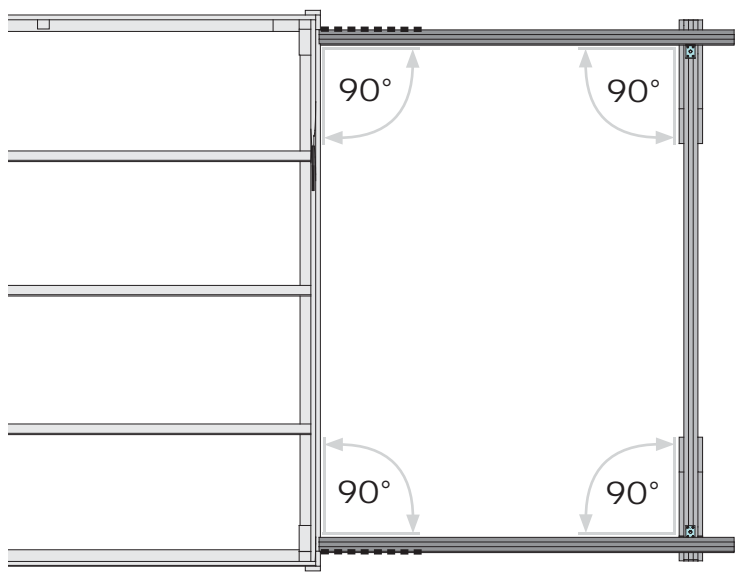



-  Bündig!
-  Flush!
-  Affleurement!
-  Gelijk!
-  I flugt!
-  Aras!
-  Combacia!
-  Stejný !

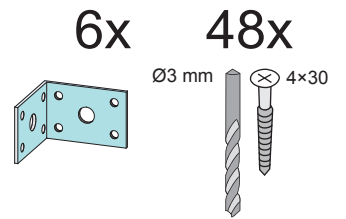
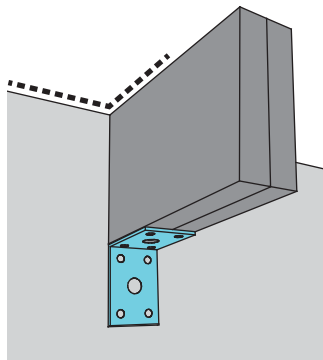

-  Draufsicht
-  Top view
-  vue de dessus
-  bovenaanzicht
-  vista desde arriba
-  vista desde arriba
-  vista dall'alto
-  pŮdorys

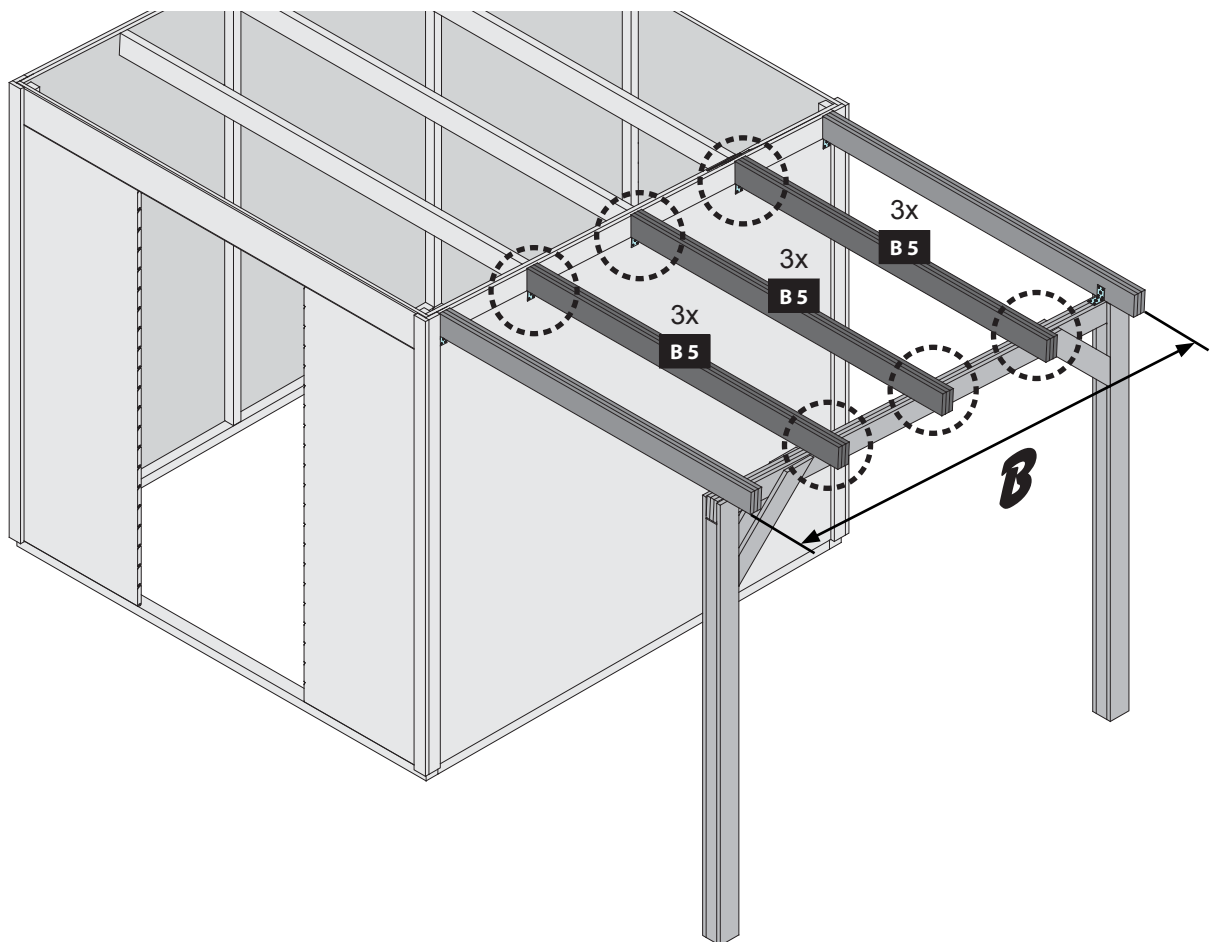
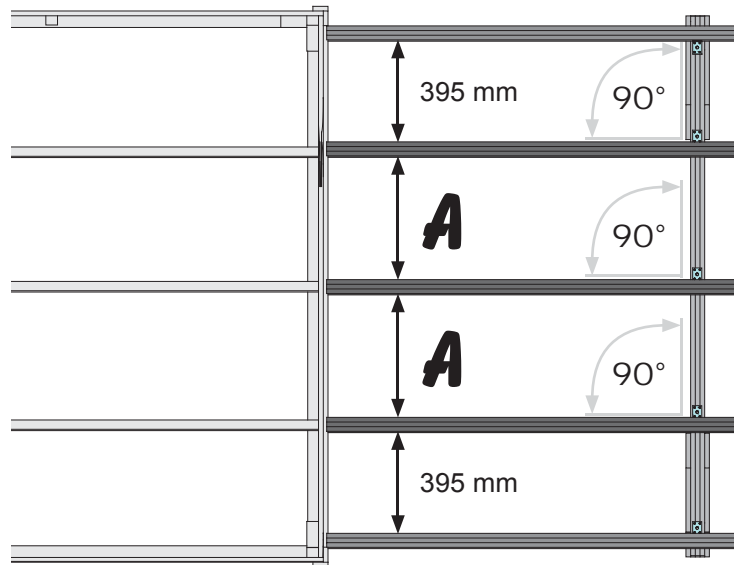

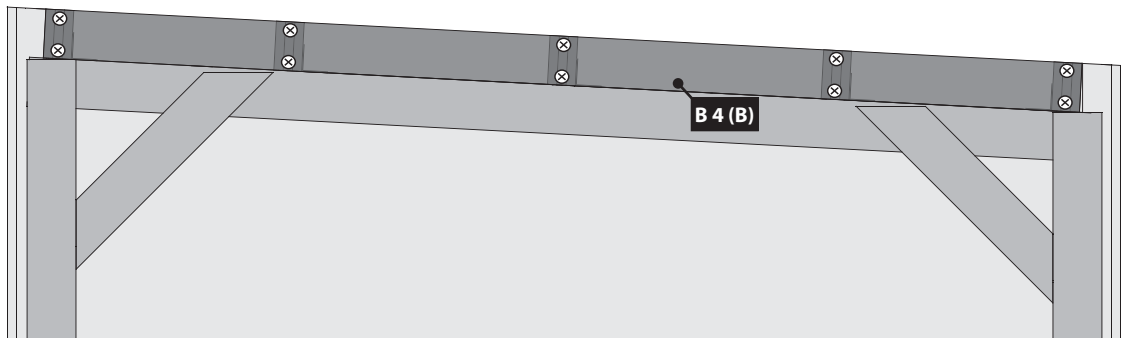
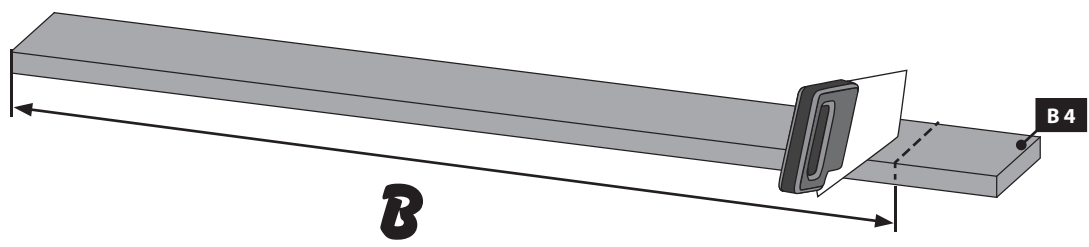

10x

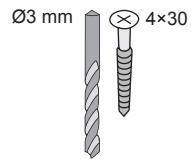

-  Bündig!
-  Flush!
-  Affleurement!
-  Gelijk!
-  I flugt!
-  Aras!
-  Combacia!
-  Stejný !

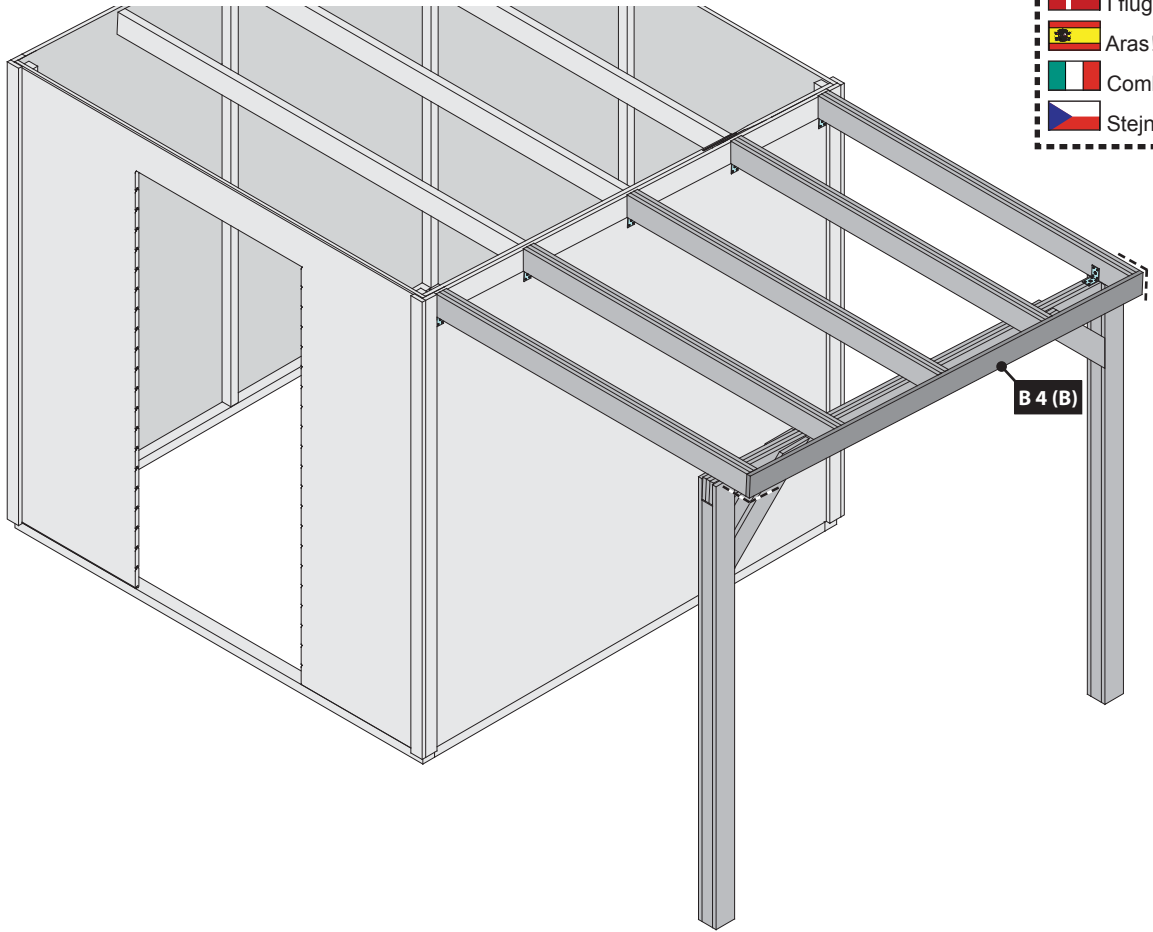

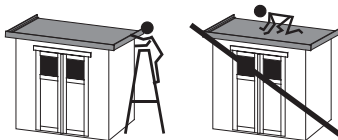

 Montage Dach

 Toit de montage

 Techo de montaje

 Montáž střechy

 Mounting roof

 Montage dak

 Tetto di montaggio

 Monterings tag

10

36x

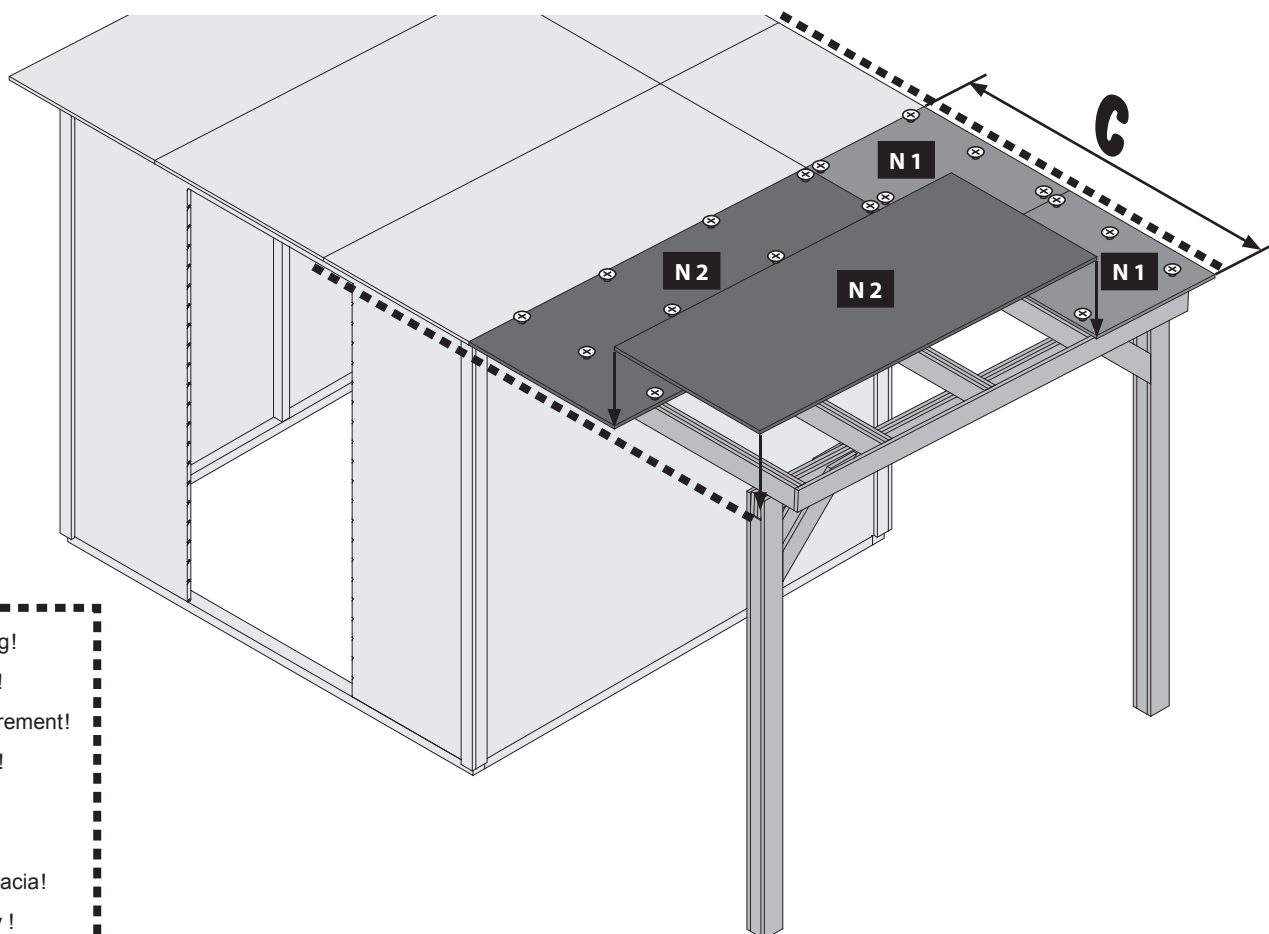
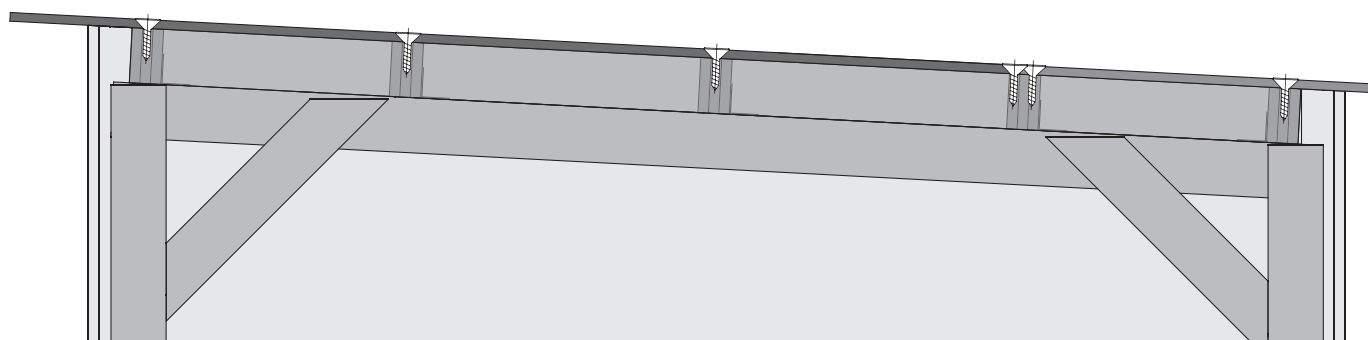
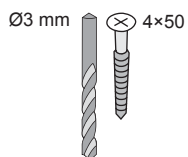

-  Bündig!
-  Flush!
-  Affleurement!
-  Gelijk!
-  I flugt!
-  Aras!
-  Combacia!
-  Stejný !

11 2x

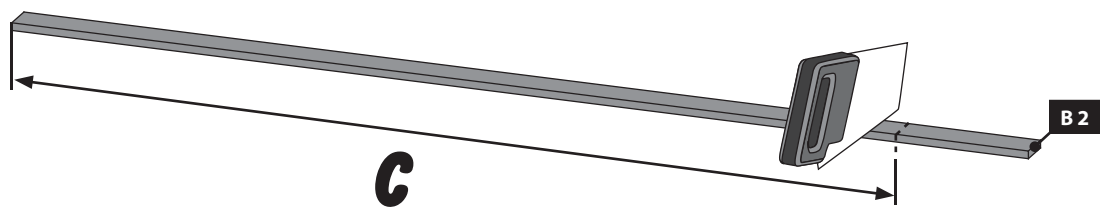

12

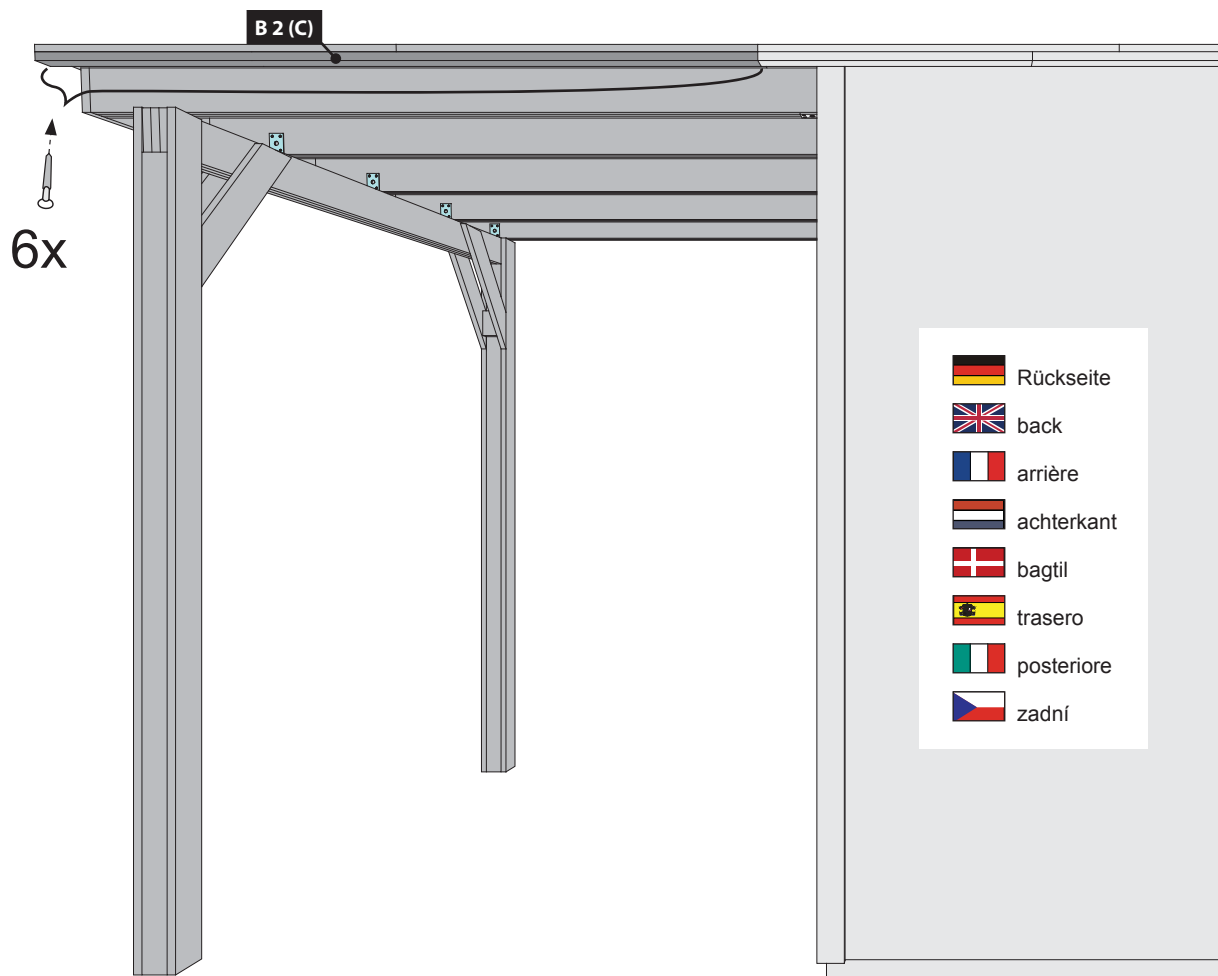





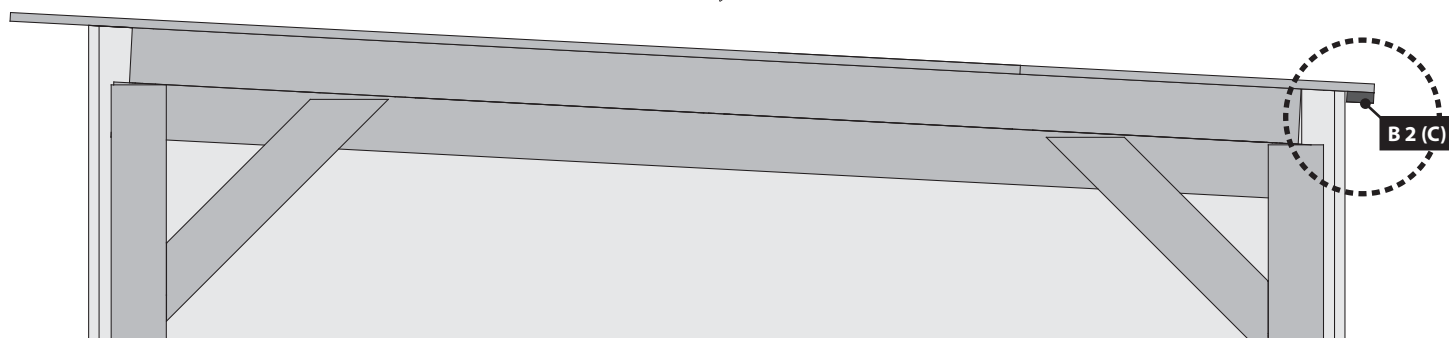
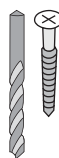

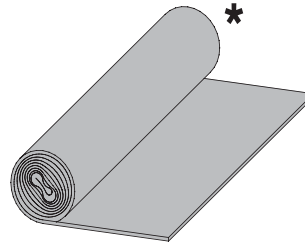
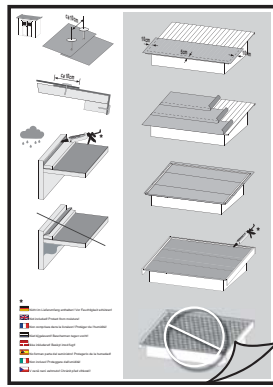

Ø3 mm 4x30

6x





\*

-  Nicht im Lieferumfang enthalten
-  Not included
-  Non comprises dans la livraison
-  Niet bijgeleverd
-  No forman parte del suministro
-  Non incluso
-  V ceně není zahrnuto
-  Ikke inkluderet

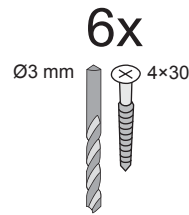

\*

-  Bestand vom Haus
-  Inventaire de la maison
-  Seulement cette maison
-  Inventaris van het huis
-  Beholdning af huset
-  Inventario de la casa
-  Inventario della casa
-  Inventář domu

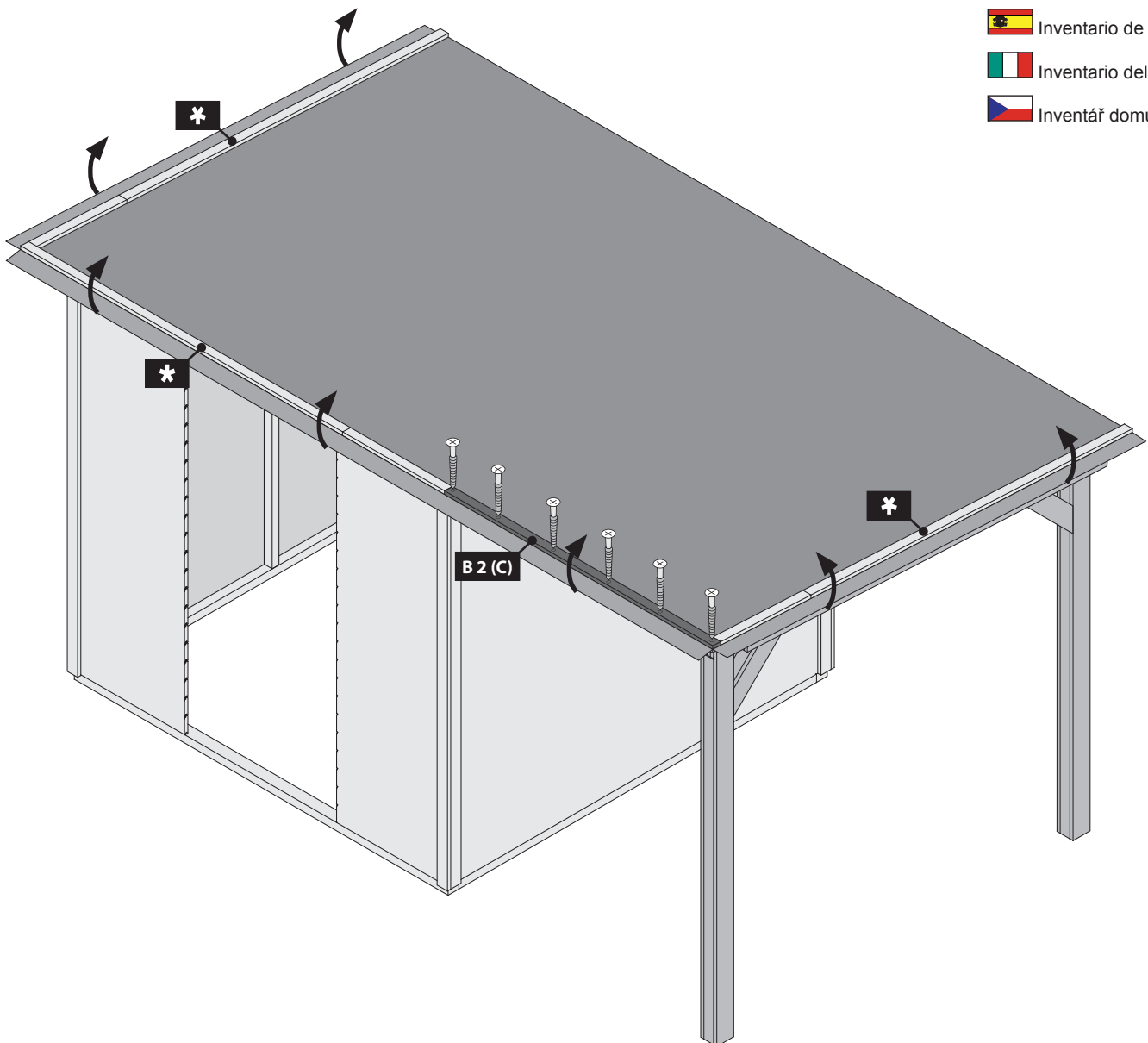

Ø3 mm 4x30

4x

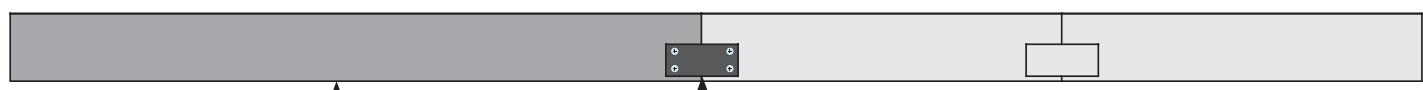
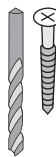

B 6

B 1

- \* Bestand vom Haus
- Inventaire de la maison
- Seulement cette maison
- Inventaris van het huis
- Beholdning af huset
- Inventario de la casa
- Inventario della casa
- Inventář domu

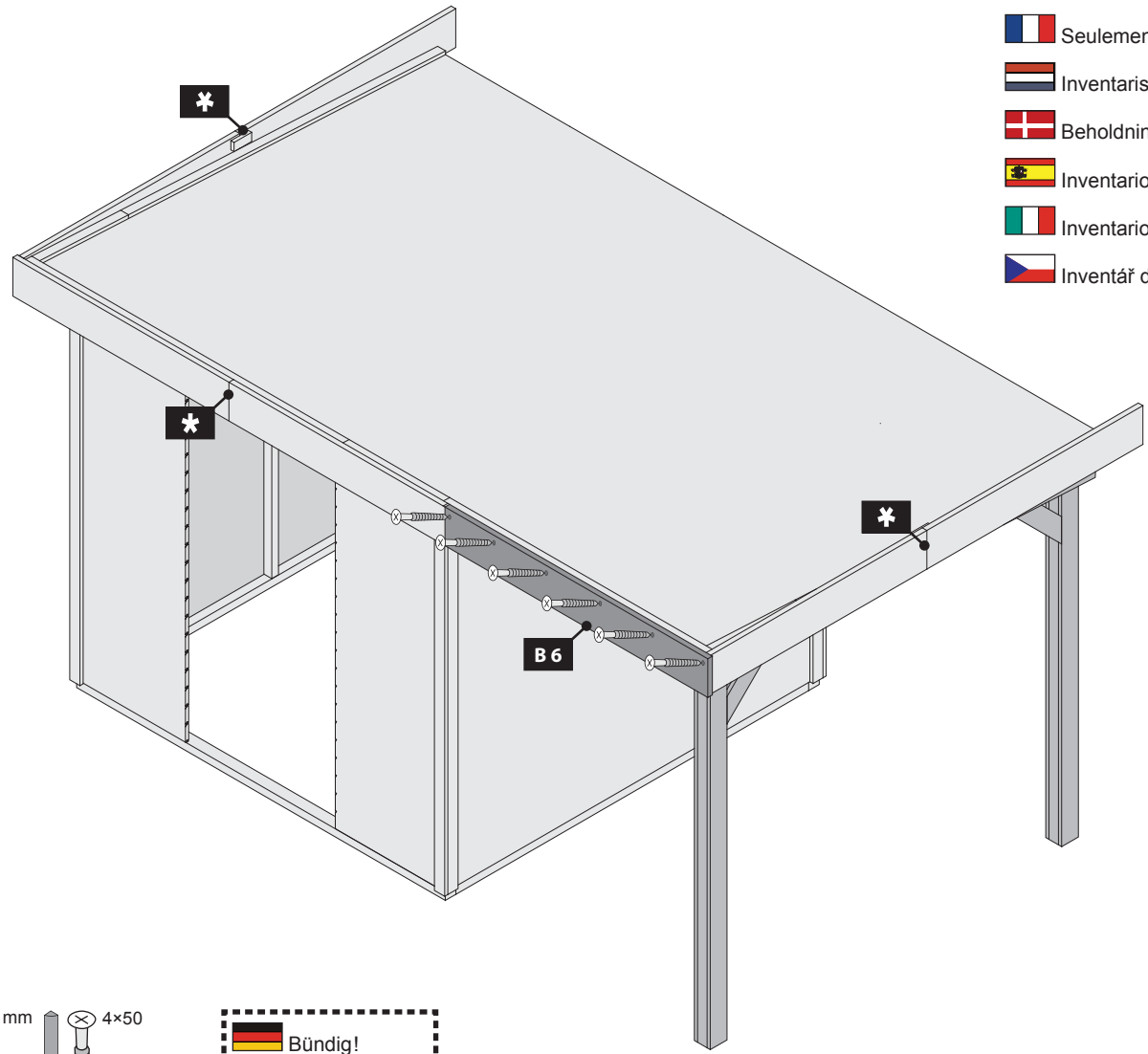

Ø3 mm 4x50

6x

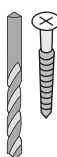

- Bündig!
- Flush!
- Affleurement!
- Gelijk!
- I flugt!
- Aras!
- Combacia!
- Stejný!

B 6

